

GT 330 A

Oil-Gas Fired Hot Water boiler

English
11/22/18

**Please Read & Save
These Instructions for
Future Reference**



Installation and operating instructions

Warning:
Before putting the boiler into operation read this manual carefully.

Warning:
The operating manual is part of the documentation that is delivered to the installation's operator. Go through the information in this manual with the owner/operator and make sure that he or she is familiar with all the necessary operating instructions.

Notice:
This manual must be retained for future reference. Improper installation, adjustment, alteration, service or maintenance can cause injury, loss of life or property damage. Refer to this manual. For assistance or additional information consult a qualified installer, service agency or the gas supplier.





85534150 E 94863873

De Dietrich

 **Warning:** indicates presence of hazards that can cause, if not avoided, severe personal injury, death or substantial property damage.

 **Caution:** indicates presence of hazards that will or can cause, if not avoided, minor personal injury or property damage.

 **Notice:**
Application comment for optimum use of equipment and adjustment as well as useful information.

 Reference to an other instruction book.

Observe the following symbols

 **DANGER**
due to explosion of gas.

- Work only on gas components when you have a license to do so.
- Note that the assembly of gas and vent connections, the initial start-up, the electrical connections, the maintenance and service can only be performed by a licensed service contractor or technician.

 **DANGER**
due to electricity.

- Prior to doing any work on the heating system, disconnect all electrical power to the boiler at the emergency switch.
- It is NOT sufficient to shut off only the boiler control!

 **CAUTION!**
SYSTEM DAMAGE
due to improper installation.

- Observe local and state codes as well as common industry practices during the installation and operation of the heating appliance.

 **CAUTION!**
SYSTEM DAMAGE
due to inadequate cleaning and maintenance.

- A boiler cleaning and maintenance should be performed annually. Verify complete system operation at the same time.
- Correct the problem immediately to prevent damage to the system!

Please observe the following safety instructions.

Read this manual carefully.

Correct installation and adjustment of the burner and the control panel is a precondition for safe, efficient operation of the gas boiler.

Read this manual and the specifications on the safety label carefully before attempting to put the burner into operation.

 **Do not store or use gasoline or other flammable liquids in the vicinity of this or any other appliance. Installation and service must be performed by a qualified installer, service agency or the gas supplier.**

WHAT TO DO IF YOU SMELL GAS:

- Do not try to light any appliance.
- Do not touch any electric switch, do not use any phone in your building.
- Immediately call your gas supplier from a neighbor's phone. Follow the gas supplier's instructions.
- If you cannot reach your gas supplier, call the Fire Department.

 **Warning:**
Improper installation, adjustment, and/or operation could cause carbon monoxide poisoning resulting in injury or death.

This product must be installed and serviced by a professional service technician who is experienced and qualified in hot water boiler installation and gas combustion.

 **Caution:** Strict compliance with these instructions is a precondition for the correct operation of the boiler.

 **IMPORTANT**
Service on this boiler should be undertaken only by trained and skilled personnel.

Keep boiler area clear and free from combustible materials, gasoline and other flammable vapors and liquids.

Do not place any obstruction in the boiler room that will hinder the flow of combustion and ventilating air.

Read these instructions carefully before proceeding with the installation of boiler. Post instructions near boiler for reference by owner and serviceman.

Maintain instructions in legible condition.

"All installations of this appliance must be in accordance to all national and local codes and authorities having jurisdiction"

[Canadian Installation] CSA B139 for Oil & CSA B149 for Gas

[USA Installations] NFPA 54/ANSI Z223.1 for Gas & NFPA 31 for Oil

This boiler must be connected to a venting that will safely and effectively discharge all flue gases to the outside in an effective manner.

Never burn garbage or paper in the unit and never leave any combustible materials around it. Do not use gasoline, crankcase draining or any other oil containing gasoline

Contents

Contents	3
Regulations and guidelines	4
Installation codes	4
General	4
1 Uncrating.....	4
2 Packing.....	4
2 Requirements for installation in the state of Massachusetts.....	4.1
2 Requirements for installation in the state of Massachusetts (continued).....	4.2
3 Technical specifications of boilers.....	5
4 Main Dimensions.....	6
Boiler Installation	7
1 Installation and clearances.....	7
2 Combustion air supply.....	7
Venting	9
1 General venting guidelines.....	9
2 Vent categories.....	9
3 Category I and II.....	10
4 Category III and IV.....	11
5 Sidewall or Direct vent.....	12
5 Sidewall or Direct vent.....	13
5 Sidewall or Direct vent.....	14
Oil or gas connections	15
1 Specific technical information supplied with the burner.....	15
Electrical	16
1 Wiring.....	16
2 Wiring procedure.....	16
3 Wiring boiler panel and general burner wiring diagrams.....	16
Start-up procedures	17
1 Start-up procedures.....	18
2 Shut-down procedures.....	19
Maintenance	20
1 Boiler.....	21
Service and maintenance schedule	22
Piping	22
1 Boiler general piping and safety components.....	22
Spare parts - GT 330 A	23-27
Control panel parts - GT 330 A	28
GT 330 A Boilersssembly	29-60

Regulations and guidelines

The installation and operating instructions shown here are given as a guide for installation and operation and are not meant to replace any State or Local Codes that may apply to the individual installation. Good engineering practice should be used. Any deviation from laws or regulations or industry Code or these instructions will void the boiler warranty and any other responsibility or liability of the De Dietrich Thermiques S.A.

Only a qualified and licenced heating professional is to carry out the removal, installation, startup and maintenance of this boiler. The boiler must be installed according to all national and local codes having jurisdiction. The operation of the boiler must be verified and all safety controls checked. Any defect or abnormal operations must be corrected immediately. The entire system requires annual service and cleaning at least once a year.

Installation codes

- THE BOILER SHALL BE ASSEMBLED AND INSTALLED BY A QUALIFIED PROFESSIONAL ONLY. STRICT COMPLIANCE WITH THESE INSTALLATION AND OPERATING INSTRUCTIONS IS A PRECONDITION FOR THE CORRECT AND GUARANTEE OF THE BOILER.
- THE INSTALLATION MUST CONFORM TO THE REQUIREMENTS OF THE AUTHORITY HAVING JURISTRICKION OR, IN THE ABSENCE OF SUCH REQUIREMENTS, TO THE CAN/CGA B-149 FUEL GAS INSTALLATION CODES AND CSA B-139 OIL INSTALLATION CODES.
- WHERE REQUIRED BY THE AUTHORITY HAVING JURISTRICKION, THE INSTALLATION MUST CONFORM TO THE STANDARD FOR CONTROLS AND SAFETY DEVICES FOR AUTOMATICALLY FIRED BOILERS ANSI/ASME CSD-1.

- THE INSTALLATION OF THE RELIEF VALVE SHALL BE CONSISTENT WITH ANSI/ASME BOILER PRESSURE VESSEL CODE, SECTION IV CSA B51.
- THE BOILER MUST NOT BE INSTALLED ON CARPETING.
- IF AN EXTERNAL ELECTRICAL SOURCE IS UTILIZED, THE BOILER WHEN INSTALLED MUST BE **ELECTRICALLY BONDED** TO GROUND IN ACCORDANCE WITH THE REQUIREMENTS OF THE AUTHORITY HAVING JURISTRICKION OR, IN THE ABSENCE OF SUCH REQUIREMENTS, WITH THE CANADIAN ELECTRICAL CODE PART 1, CSA C22.1

 **LABEL ALL WIRES PRIOR TO DISCONNECTION WHEN SERVICING CONTROLS. WIRING CAN CAUSE IMPROPER OPERATION AFTER SERVICINGS. "VERIFY PROPER OPERATION AFTER SERVICE".**

General

The **GT330 A series** are oil or gas fired, cast iron, automatic boilers.

1 Uncrating

Upon arrival, check shipment to ensure all parts have been shipped. Inspect all items for delivery damage. Report all damages and shortages to the delivery carrier. Report any damage and shortages to the Distributor.

2 Packing

See the separate assembly instruction book.

For the optional equipment you may use with this boiler, see the current price list.

Requirements for installation in the state of Massachusetts

Boiler Installations within the Commonwealth of Massachusetts must conform to the following requirements:

- Boiler must be installed by a plumber or a gas fitter who is licensed within the Commonwealth of Massachusetts.
- Prior to unit operation, the complete gas train and all connections must be leak tested using a non-corrosive soap.
- The vent termination must be located a minimum of 4 feet above grade level. If side-wall venting is used, the installation must conform to the following requirements **extracted from 248 CMR 5.08 (2)**:

(a) For all side wall horizontally vented gas fueled equipment installed in every dwelling, building or structure used in whole or in part for residential purposes, including those owned or operated by the Commonwealth and where the side wall exhaust vent termination is less than seven (7) feet above finished grade in the area of the venting, including but not limited to decks and porches, the following requirements shall be satisfied:

1. INSTALLATION OF CARBON MONOXIDE DETECTORS: At the time of installation of the side wall horizontal vented gas fueled equipment, the installing plumber or gasfitter shall observe that a hard wired carbon monoxide detector with an alarm and battery back-up is installed on the floor level where the gas equipment is to be installed. In addition, the installing plumber or gasfitter shall observe that a battery operated or hard wired carbon monoxide detector with an alarm is installed on each additional level of the dwelling, building or structure served by the side wall horizontal vented gas fueled equipment. It shall be the responsibility of the property owner to secure the services of qualified licensed professionals for the installation of hard wired carbon monoxide detectors.

a. In the event that the side wall horizontally vented gas fueled equipment is installed in a crawl space or an attic, the hard wired carbon monoxide detector with alarm and battery back-up may be installed on the next adjacent floor level.

b. In the event that the requirements of this subdivision cannot be met at the time of completion of installation, the owner shall have a period of thirty (30) days to comply with the above requirements; provided, however, that during said thirty (30) day period, a battery operated carbon monoxide detector with an alarm shall be installed.

2. APPROVED CARBON MONOXIDE DETECTORS: Each carbon monoxide detector as required in accordance with the above provisions shall comply with NFPA 720 and be ANSI/UL 2034 listed and IAS certified.

3. SIGNAGE: A metal or plastic identification plate shall be permanently mounted to the exterior of the building at a minimum height of eight (8) feet above grade directly in line with the exhaust vent terminal for the horizontally vented gas fueled heating appliance or equipment. The sign shall read, in print size no less than one-half (1/2) inch in size, "**GAS VENT DIRECTLY BELOW. KEEP CLEAR OF ALL OBSTRUCTIONS**". (Continued)

Regulations and guidelines

Requirements for installation in the state of Massachusetts (continued)

4. INSPECTION: The state or local gas inspector of the side wall horizontally vented gas fueled equipment shall not approve the installation unless, upon inspection, the inspector observes carbon monoxide detectors and signage installed in accordance with the provisions of 248 CMR 5.08(2)(a)1 through 4.

(b) EXEMPTIONS: The following equipment is exempt from 248 CMR 5.08(2)(a)1 through 4:

1. The equipment listed in Section 10 entitled "Equipment Not Required To Be Vented" in the most current edition of NFPA 54 as adopted by the Board; and
2. Product Approved side wall horizontally vented gas fueled equipment installed in a room or structure separate from the dwelling, building or structure used in whole or in part for residential purposes.

(c) MANUFACTURER REQUIREMENTS - GAS EQUIPMENT VENTING SYSTEM PROVIDED. When the manufacturer of Product Approved side wall horizontally vented gas equipment provides a venting system design or venting system components with the equipment, the instructions provided by the manufacturer for installation of the equipment and the venting system shall include:

1. Detailed instructions for the installation of the venting system design or the venting system components; and
2. A complete parts list for the venting system design or venting system.

(d) MANUFACTURER REQUIREMENTS - GAS EQUIPMENT VENTING SYSTEM NOT PROVIDED. When the manufacturer of a Product Approved side wall horizontally vented gas fueled equipment does not provide the parts for venting the flue gases, but identifies "special venting systems", the following requirements shall be satisfied by the manufacturer:

1. The referenced "special venting system" instructions shall be included with the appliance or equipment installation instructions; and
2. The "special venting systems" shall be Product Approved by the Board, and the instructions for that system shall include a parts list and detailed installation instructions.

(e) A copy of all installation instructions for all Product Approved side wall horizontally vented gas fueled equipment, all venting instructions, all parts lists for venting instructions, and/or all venting design instructions shall remain with the appliance or equipment at the completion of the installation.

.....[End of Extracted Information From 248 CMR 5.08 (2)].....

Item	Unit	Model						
		GT 334 A	GT 335 A	GT 336 A	GT 337 A	GT 338 A	GT 339 A	
Firing Sequence		Consult Burner Technical Data						
[CSA] - Gas Input	MBH	404	598	808	1,024	1,226	1,442	
	kW	118	175	237	300	359	423	
[CSA] - # 2 Fuel Oil Input	US GPH	2.80	4.15	5.60	7.10	8.50	10.00	
[CSA] - Output [Gas-Oil]	MBH	343	509	686	870	1,042	1,226	
	kW	100.6	149.1	201.2	255.1	305.3	359.2	
[NET] - Output [Gas-Oil]	MBH	298	442	597	757	906	1,066	
Cast Iron Sections	#	4	5	6	7	8	9	
Flue-way baffles	#	6	10	10	10	12	12	
Water Capacity	US Gal	25.37	30.65	35.94	41.22	46.51	51.80	
	Liter	96	116	136	156	176	196	
Water Resistance [$\Delta T = ^\circ F$]	18° F	Ft. H ₂ O	0.368	0.60221	1.0371	1.539	2.275	3.5129
	27° F	Ft. H ₂ O	0.1539	0.24758	0.47508	0.6524	1.007	1.539
	36° F	Ft. H ₂ O	0.0869	0.1405	0.26765	0.36802	0.56876	0.86986
Combustion Chamber Dimensions	Diameter [equivalent]	Inch	14.84					
		mm	377					
	Depth	Inch	24.45	30.75	37.05	43.35	49.65	54.96
		mm	621	781	941	1,101	1,261	1,396
	Volume	Ft ³	3.39	4.31	5.23	6.14	7.06	7.98
m ³		0.096	0.122	0.148	0.174	0.2	0.226	
MAWP [Water]	PSI	ASME IV Rating Class 30 - (90 PSI) [See Canadian Provincial CRN approvals]						
Min. Safety Relief Capacity	MBH	343	509	686	870	1,042	1,226	
S3NA MD5 Panel	Electrical Connection	V/P/H	120/1/60					
	Max. Water Temp. Safety Limit [MR]	° F	248					
		° C	120					
	Water Operating Temperature Range	° F	104 - 185					
° C		40 - 85						
Chamber Resistance	Inch w.c.	0.80	0.16	0.28	0.48	0.72	0.88	
	mbar	0.2	0.4	0.7	1.2	1.8	2.2	
Gas-Vent Category	#	I, II - III or IV						
Boiler Vent Connection	Inch	7	7	7	8	8	8	
Weight [Dry]	lb	1,124	1,340	1,530	1,744	1,953	2,154	
	kg	510	608	694	791	886	977	

Note:

- CSA - MBH Output based on Thermal Efficiency Test According to ANSI Z21.13a/CSA 4.9a-2005
- All Models Certified for 0 - 2,000 feet ASL installation altitude, consult factory for higher altitudes
- [NET] MBH Output Factor 1.15, Allowance for Piping and Pickup Losses
- Chamber Resistance Based on Neutral Chimney-Vent Pressure
- Gas Vent Category Based on Several Factors [CO₂ content, Vent Pressure & Net-Flue Gas Temp]
- Approved for Direct-Vent, Use Only Approved Venting as Listed
- Natural Draft Applications, Approved for Type L vent [Gas-Oil] or Type B Vent [Gas Only]
- Conversion Btu to kW = 3,412 Btu per kW
- All Models are Design Certified & Eligible to Bear Approval Marking as Shown.
- All Models Certified to Fire; # 2 oil, Natural & Propane Gases. Consult factory for Available Burners.
- All Models Comply and Certified in Accordance to the latest Canadian & US standards
- To Obtain Current IBR Ratings, consult their publications and website.

Due to ongoing and continuous product improvements, Flexible Eutectic Sales Ltd. Reserves all rights to amend and delete information provided on this product specification table.

4 Main Dimensions

GT 330 A

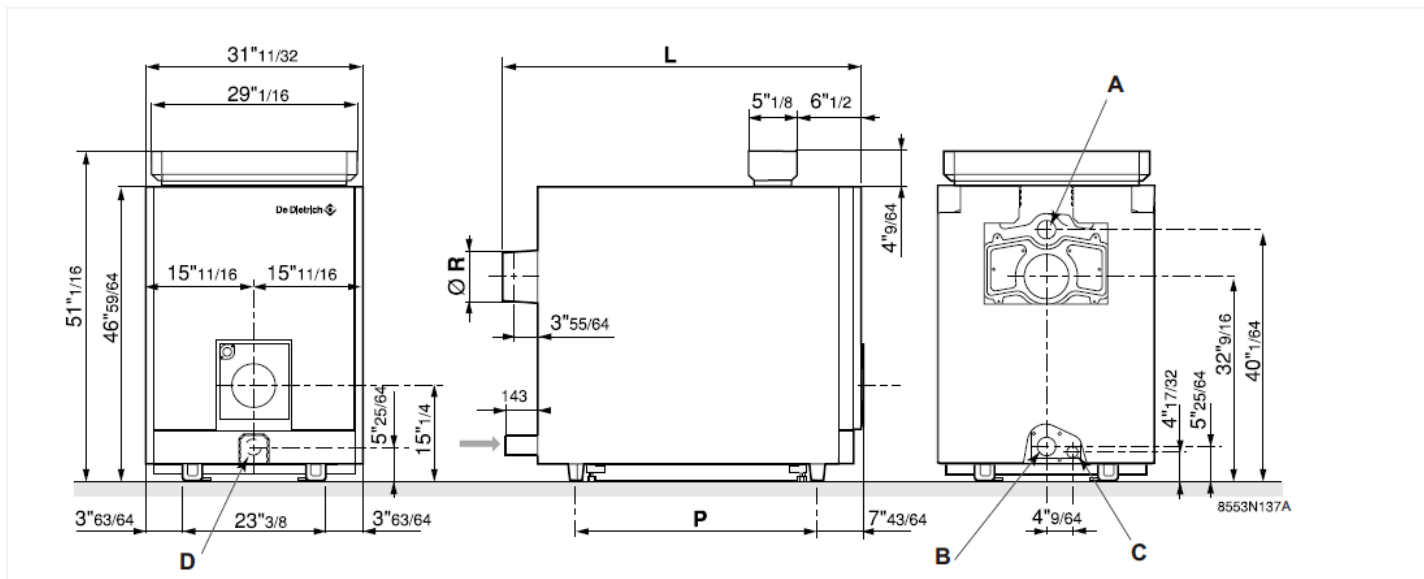

A Water flow tapping 2 1/2" NPSC female

C Drain 1 1/2" FPT

B Water return 2 1/2" NPSC female with supplied non-flanged distributor tube from GT 336A to 339A.

D Rp 2 1/2" diameter sludge removal hole

Type of boiler	GT 334 A	GT 335 A	GT 336 A	GT 337 A	GT 338 A	GT 339 A
L	38 ^{5/8} "	44 ^{59/64} "	51 ^{7/32} "	57 ^{33/64} "	63 ^{13/16} "	70 ^{7/64} "

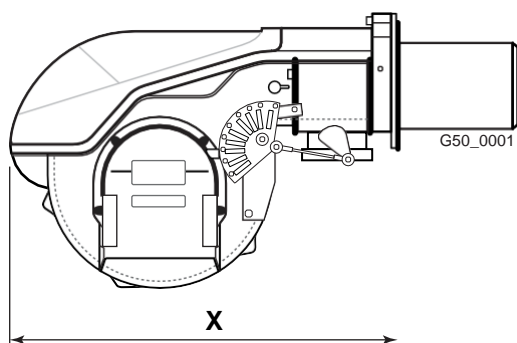

P	19 ^{9/32} "	25 ^{19/32} "	31 ^{7/8} "	38 ^{3/16} "	44 ^{31/64} "	50 ^{25/32} "
Ø R	7"	7"	7"	8"	8"	8"

Dimension "X" Max. Burner Length (inches)					
Boiler Model	Riello	Weishaupt	Power Flame	Fuel Master	Gordon Piatt
GT334 A	10	19	22 ^{1/4}	19 ^{1/4}	26
GT335 A					
GT336 A	26 ^{15/32}	23	25 ^{1/8}	19 ^{1/4}	26
GT337 A					
GT338 A					
GT339 A					

Notes:

- Dimension are for gas burner only
- Oil and combination oil/gas, refer to burner manufacturer specifications

Boiler Installation

1 Installation

The GT 330A boiler has a base frame, although a housekeeping pad is recommended to keep steel parts out of casual water. Its furnace is closed, so it is not necessary to place it on a fireproof floor, but the floor must be able to bear the weight.

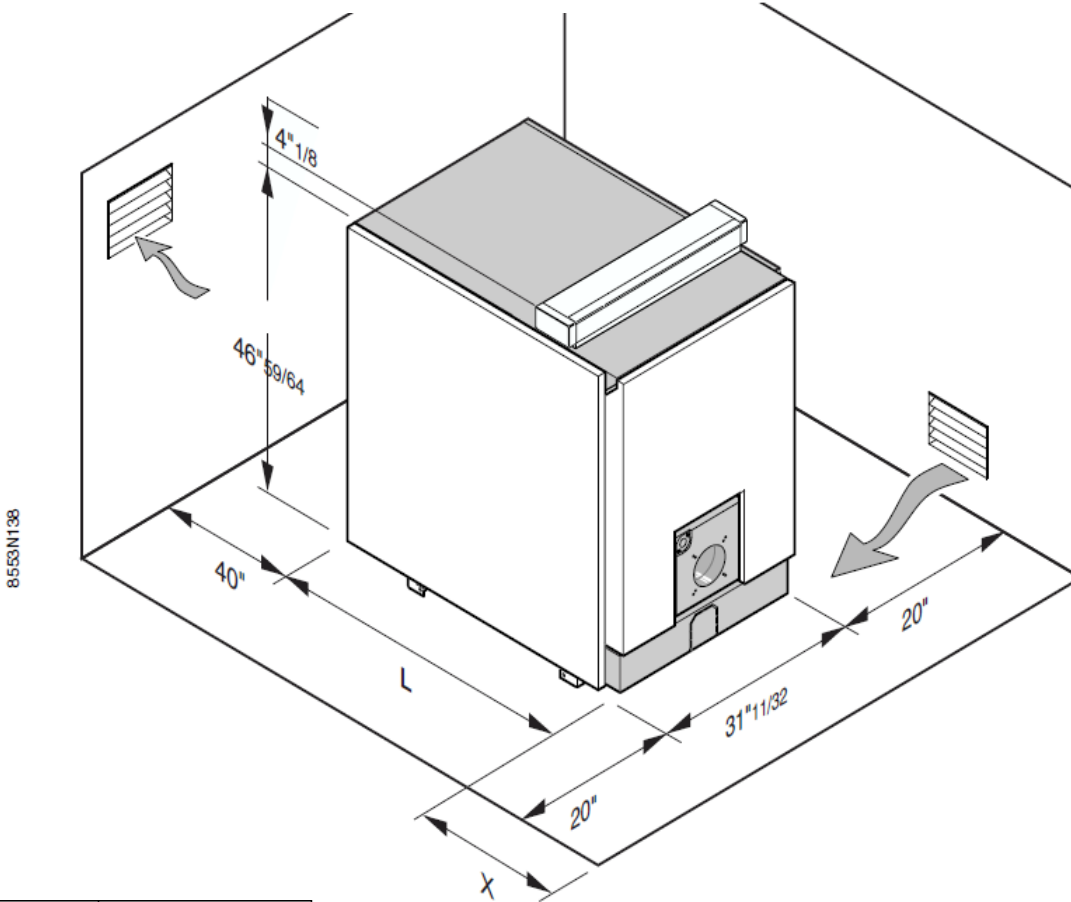

Dimension 'X', consult burner info. additional 24 inches for servicing
 Caution : note additional space required when the burner door is open.
 Multiple installation of several boilers side by side, these dimensions need to be modified.

Illustration above showing minimum distances to combustible materials and servicing.

Boiler must not be installed on combustible material or on carpet.

Boiler type	L
GT 334 A	33"
GT 335 A	39 ^{5/16} "
GT 336 A	45 ^{9/16} "
GT 337 A	51 ^{7/8} "
GT 338 A	58 ^{3/16} "
GT 339 A	64 ^{1/2} "

2 Combustion Air Supply

Boilers operating in atmospheres that contain fluorides or chlorides such as beauty shops and automotive repair garages where air conditioning services are performed or industrial applications that may have corrosive elements in the air must have a clean source of combustion and ventilation air. Boiler damage by contaminants will void the warranty and any other responsibility or liability of De Dietrich Thermique/FES Ltd.

Warning: Ensure boiler room is adequately ventilated and clear and free from combustible materials, gasoline and other flammable vapours and liquids.

Combustion air supply must be provided according to national and local codes:
 CSA B149.1 -.2 & CSA B139
 ANSI Z223.1 & NFPA 31

5. Boiler Venting & Chimney General



Caution & Warning:

It is advised and recommended that the heating contractor-professional apply vent materials that are approved and agency listed. Installation of any venting must follow all local codes in conjunction with vent manufacturer instructions and appliance manufacturer instructions.

All De Dietrich GT series oil-gas fired cast iron boilers are high performance boilers that could operate under all 4 vent categories as established by ANSI Z21.13/CSA 4.9 Standard. To assist with application where the vent category is unknown a graph below has been provided to assist you in determining the vent category and what venting materials would be acceptable. Although the gas vent categories were developed specifically for gas fired appliances, using this information is helpful for oil fired boilers. It is very important the venting be selected according to the conditions that the boiler will operate under, minimum and maximum firing conditions of the boiler must be respected. The venting installed must comply and be certified to all applicable codes and standards for each jurisdiction.

Gas-Vent Category [4] Definitions:

- Cat. I**
A Boiler, which operates with a non-positive vent (breach) pressure and flue gas temperatures which avoids excessive condensation production in the chamber and venting.
- Cat. II**
A Boiler, which operates with a non-positive vent (breach) pressure and flue gas temperatures produce condensation production in the chamber and venting.
- Cat. III**
A Boiler, which operates with a positive vent (breach) pressure and flue gas temperatures which avoids excessive condensation production in the chamber and venting.
- Cat. IV**
A Boiler, which operates with a positive vent (breach) pressure and flue gas temperatures produces condensation production in the chamber and venting.

Chart A

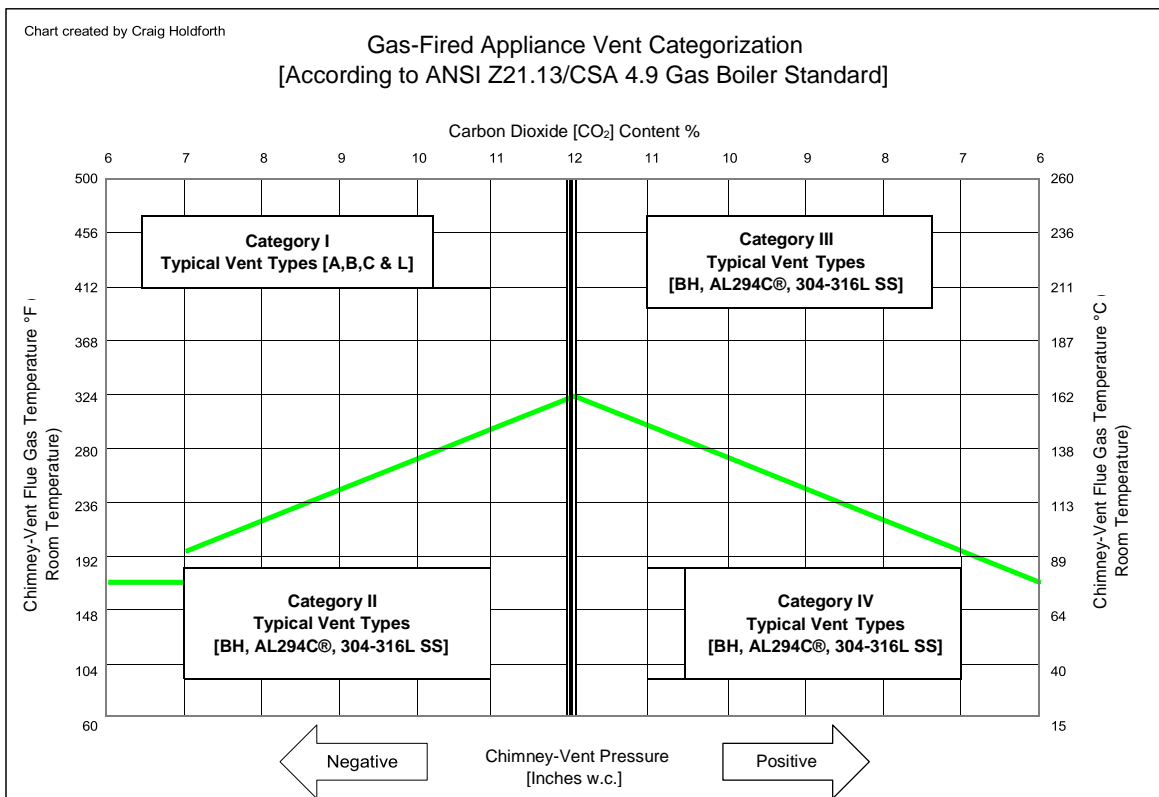

5.1 Boiler Venting – Category I & II Typical Layouts and Requirements.



Caution & Warning:

Improperly sealed venting system could result in carbon monoxide [CO] poisoning; ensure adequate support and fastening of the system. Ensure venting can safely exhaust all flue gases outside in an effective manner. These systems must operate under a negative vent pressure condition that is stable.



Warning & Cautions for Co-Venting:

Co-venting with other appliances shall conform latest ANSI Z223.1 & CAN/CGA 149 installation codes, any improper operation shall be corrected, the common venting shall be sized according to the appropriate tables in Part II of the above mentioned codes.

Category I Vent Systems Requirements:

1. Flue gas temperatures above the green line shown in chart A.
2. Approved type of venting for category I appliances.
3. A barometric draft control maybe employed as required, but is not necessary for correct boiler operation. Consult a chimney-vent specialist for correct application and usage.
4. Breeching and chimney vent sized in accordance to local and national codes or by good engineering methods.
5. Vent safety device equipped on the venting or as equipped on burner.
6. Condensate TEE fitting supplied on the boiler breeching as close as possible and be orientated to avoid accumulation of flue gas condensation in the boiler or venting is also used to determine flue gas emissions.

Category II Vent Systems Requirements:

1. Flue gas temperatures below the green line shown in chart A.
2. Approved type of venting for category II appliances.
3. A barometric draft control maybe employed as required, but is not necessary for correct boiler operation. Consult a chimney-vent specialist for correct application and usage.
4. Breeching and chimney vent sized in accordance to local and national codes or by good engineering methods.
5. Vent safety device equipped on the venting or as equipped on burner.
6. Condensate TEE fitting supplied on the boiler breeching as close as possible and be orientated to avoid accumulation of flue gas condensation in the boiler or venting is also used to determine flue gas emissions.

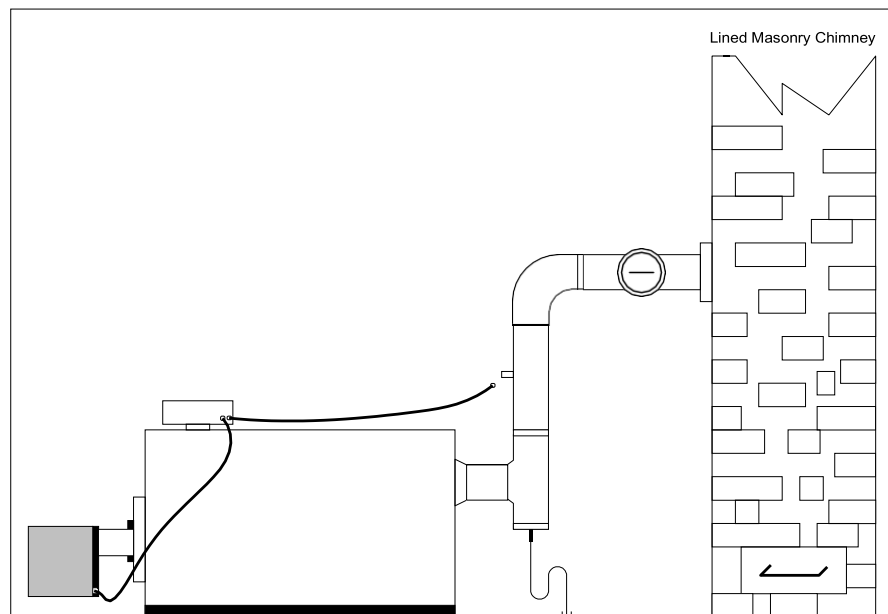

Caution-Warning:

Flue gas condensation is very aggressive and corrosive which could lead to failure of the venting system or drains, consult local and national codes regarding flue gas condensation disposal. The P-trap assembly must be properly filled with water to avoid escape of flue gas emissions. The flue gas condensation may require neutralization prior to entering the drain.

5.2 Boiler Venting – Category III & IV Vent Systems Typical Layouts and Requirements.



Caution & Warning:

Improperly sealed venting system could result in carbon monoxide [CO] poisoning; ensure adequate support and fastening of the system. Ensure venting can safely exhaust all flue gases outside in an effective manner. These systems must operate under a positive vent pressure condition that is stable.



Warning & Cautions for Co-Venting:

Co-venting with other appliances shall conform latest ANSI Z223.1 & CAN/CGA 149 installation codes, any improper operation shall be corrected, the common venting shall be sized according to the appropriate tables in Part II of the above mentioned codes.

Category III Vent Systems Requirements:

1. Flue gas temperatures above the green line shown in chart A.
2. Approved type of venting for category III appliances
3. Breeching and chimney diameter sized in accordance to national & local codes or by good engineering methods.
4. Vent safety device equipped on burner [MR]
5. Condensate TEE fitting supplied on the boiler breeching as close as possible and be orientated to avoid accumulation of flue gas condensation in the boiler or venting.

Category IV Vent Systems Requirements:

1. Flue gas temperatures below the green line shown in chart A.
2. Approved type of venting for category IV appliances
3. Breeching and chimney diameter sized in accordance to national & local codes or by good engineering methods.
4. Vent safety device equipped on burner [MR]
5. Condensate TEE fitting supplied on the boiler breeching as close as possible and be orientated to avoid accumulation of flue gas condensation in the boiler or venting.

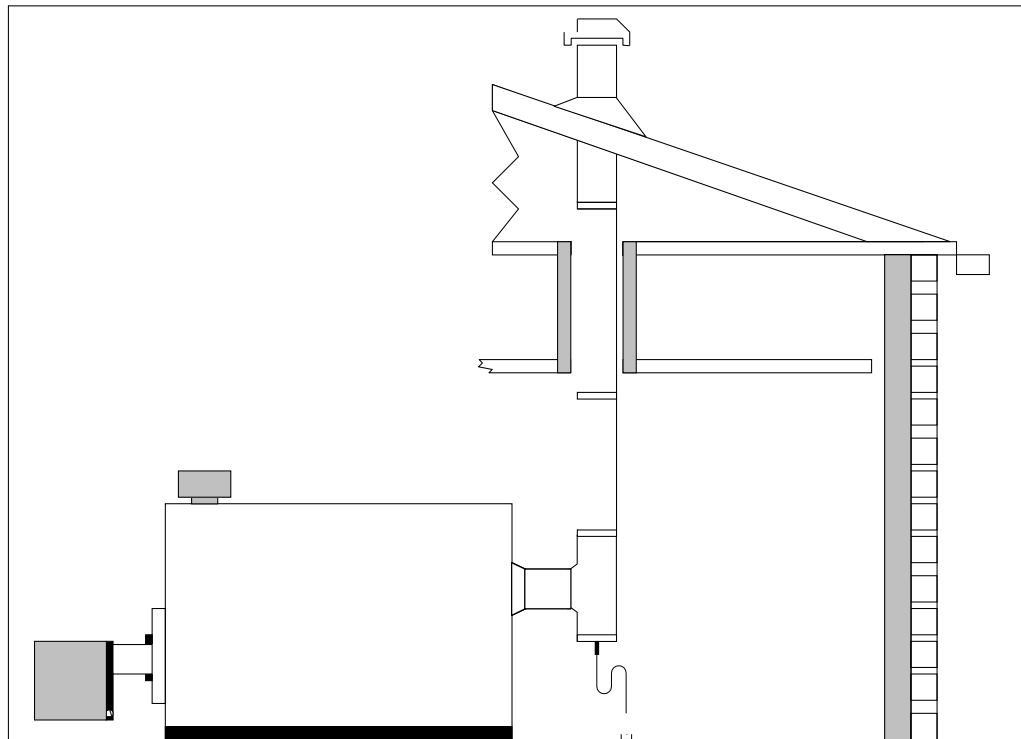

Caution-Warning:

Flue gas condensation is very aggressive and corrosive which could lead to failure of the venting system or drains, consult local and national codes regarding flue gas condensation disposal. The P-trap assembly must be properly filled with water to avoid escape of flue gas emissions. The flue gas condensation may require neutralization prior to entering the drain.

5.3 Boiler Venting – Side-Wall or Direct Vent Systems Typical Layouts and Requirements.

CAUTION!  **Caution & Warning:** Improperly sealed venting system could result in carbon monoxide [CO] poisoning; ensure adequate support and fastening of the system. Ensure venting can safely exhaust all flue gases outside in an effective manner. These systems must operate under a positive vent pressure condition that is stable. Do not Co-Vent with any other appliance, the venting system was designed for single appliance venting only.

Side-wall & Direct Vent Systems:

These systems do not fall under any of the gas vent categories, these systems are pre-engineered. These applications of this venting system must be followed exactly, for safe, efficient and trouble free operation.

System Requirements:

1. Venting sized accordance to direct vent table
2. Type “BH” [AL294C®] vent material
3. Condensate TEE fitting supplied on the boiler breeching as close as possible and be orientated to avoid accumulation of flue gas condensation in the boiler or venting is also used for determining flue gas emissions.
4. Vent termination TEE
5. Vent safety device equipped on burner [MR]

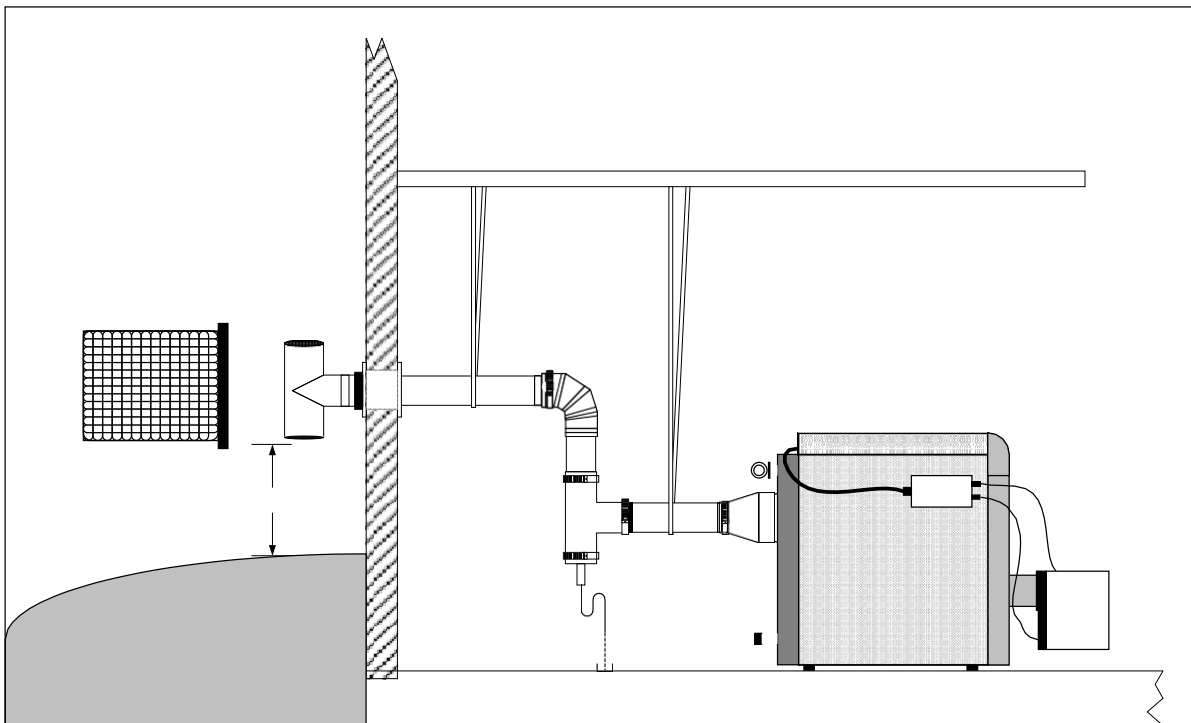

Vent Termination Locations & Warning – See Section 5.5

Caution-Warning:

Flue gas condensation is very aggressive and corrosive which could lead to failure of the venting system or drains, consult local and national codes regarding flue gas condensation disposal. The P-trap assembly must be properly filled with water to avoid escape of flue gas emissions. The flue gas condensation may require neutralization prior to entering the drain.

5.4 Boiler Venting – Side-wall or Direct Vent Systems Sizing Tables & Vent Safety Device

- All venting lengths must be calculated to equivalent lengths, all application must include at least one 90° elbow
- Venting must be a type 'BH' [AL294C® material]
- Maximum vent length [equivalent] = 30 ft. [9m]
- Minimum vent length [equivalent] 5 ft. [1.5m]
- Maximum number of 90° elbows = 2 or 3 45° elbows, each 90° elbow is equivalent to 10 ft. or straight pipe, the 45° elbow is equivalent = 5 ft.
- Condensate TEE must be provided [equivalent length = 7 ft.]
- Appliance reducing adapter [equivalent length 3 ft.]
- Sealed combustion, combustion air intake sizing, must be sized according to the burner manufacturer's instructions
- Vent [breaching] pressure shall not exceed 0.20 inches w.c. [0.50 mbar]
- Vent termination must be a TEE type, follow warning regarding termination locations. Do not include the termination TEE length in the vent length calculation.
- Venting shall be sloped, so any condensation developed will drain through the condensate TEE fitting
- Vent safety device, differential air pressure switch [manual reset] NC switch opens on rise of pressure.
- Optional function of power burners which can employ an post purge function to exhaust flue gases for a fixed time [1 minute to 4 minutes maximum]
- Burner employing a standby air damper closed position, the closed position should be slightly opened to allow hot flue gases to escape upward through venting and not be entrapped in the combustion head. Important note, that in negative building pressures, the observation and odor of flue gases may enter the boiler room.

Determining vent length [equivalent] Example:

Appliance reducing adapter	[x1] = 3 ft.
Condensate TEE	[x1] = 7 ft.
12" vent straight vent pipe	[x3] = 3 ft.
Elbow 90°	[x1] = 10 ft.
Termination TEE	[x1] = 0 ft.
Length [equivalent] =	23 ft.

GT 330 A Series

Model	Boiler Connection ø	Oil-Gas Vent ø	[Δp] Pressure switch Setting [inches w.c.]
GT 334 A	7 inch	7 inch	Set vent safety pressure switch 150% above burner gas manifold or head pressure setting
GT 335 A	7 inch	7 inch	
GT 336 A	7 inch	7 inch	
GT 337 A	8 inch	8 inch	
GT 338 A	8 inch	8 inch	
GT 339 A	8 inch	8 inch	

5.5 All Side-wall and direct Vent termination locations installation precautions:



Warning/Caution:

In all cases avoid potential vent termination locations where excess debris or snow could accumulate and block the vent termination to any degree.

Minimum clearance of 4 ft. [1.22m] horizontally from, and in no case above or below, unless a 4 foot [1.22m] horizontal distance is maintained, from electric meters, gas meters, regulators & relief equipment.

Do Not Co-Vent Any Direct Vent or Sidewall Venting System

<p>B149.1 (GAS INSTALLATIONS CANADA)</p>
<p>A VENT SHALL NOT TERMINATE.....</p> <p>Directly above a paved sidewalk or driveway which serves 2 buildings. Less than 7 ft. any paved sidewalk or drive way Less than 6 ft. of a combustion air inlet to any building Less than 4 ft. above a meter/regulator assembly [horizontally] of the vertical center-line of the regulator vent outlet to a maximum vertical distance of 15 ft. Less than 4 ft. of any gas service regulator vent outlet Less than 1 ft. above grade or normal anticipated snow level for the area Less than 3 ft. from windows, doors [that can be opened], combustion air supply or any appliance or building. Underneath a veranda, porch or deck unless:</p> <ol style="list-style-type: none"> 1. The veranda, porch or deck is fully open on a minimum of 2 sides beneath the floor & 2. The distance between the top of the vent termination and the underside of the veranda, porch or deck is greater than 1 ft.

<p>B139-00 (OIL INSTALLATIONS CANADA)</p>
<p>A VENT SHALL NOT TERMINATE.....</p> <p>Directly above a paved sidewalk or driveway which serves 2 buildings. Less than 7 ft. any paved sidewalk or drive way Less than 6 ft. from an open-able window, door or mechanical combustion air supply Less than 6 ft. of any combustion air inlet Less than 3 ft. of the vertical centerline of the meter/regulator assembly on a horizontal plane perpendicular to the regulator Less than 6 ft. of gas service regulator vent outlet Less than 4 ft. of oil tank vent or oil tank fill inlet Less than 1 ft. above grade or normal anticipated snow level for the area. Within 6 ft. of a property line Underneath a veranda, porch or deck Flue gases are within 6 ft. of combustible material or any openings of surrounding buildings. Less than 3 ft. from an inside corner or L-shaped structure Where flue gases may be directed towards brickwork, siding or other construction that may cause damaged from heat or condensate from the flue gases.</p>

<p>NFPA 54 / ANSI Z223 (GAS INSTALLATIONS USA)</p>
<p>A VENT SHALL NOT TERMINATE.....</p> <p>Less than 3 ft. of any combustion air inlet source located within 10 ft. Less than 1 ft. from any obstructions Less than 1 ft. above grade or normal anticipated snow level for the area. Over public walkways, driveways or other areas where condensate or vapor could create nuisance or hazard or could be detrimental to the operation of regulators, relief's, valves or other equipment</p>

<p>NFPA 31 (OIL INSTALLATIONS USA)</p>
<p>A VENT SHALL NOT TERMINATE.....</p> <p>Less than 5 ft. from vent outlet of the supply tank Less than 7 ft. above walkways Less than 1 ft. from any door, window or air inlet source Less than 1 ft. from grade or snow level. Less than 3 ft. from a air intake that is within 10 ft Less than 1 ft. from soffit of the roof Less than 3 ft. from any building corner or L shape structure</p>



WARNING-CAUTION

Consult Local Codes & Authorities for other Requirements not mentioned

6 Dimensional information required for connection of the boiler

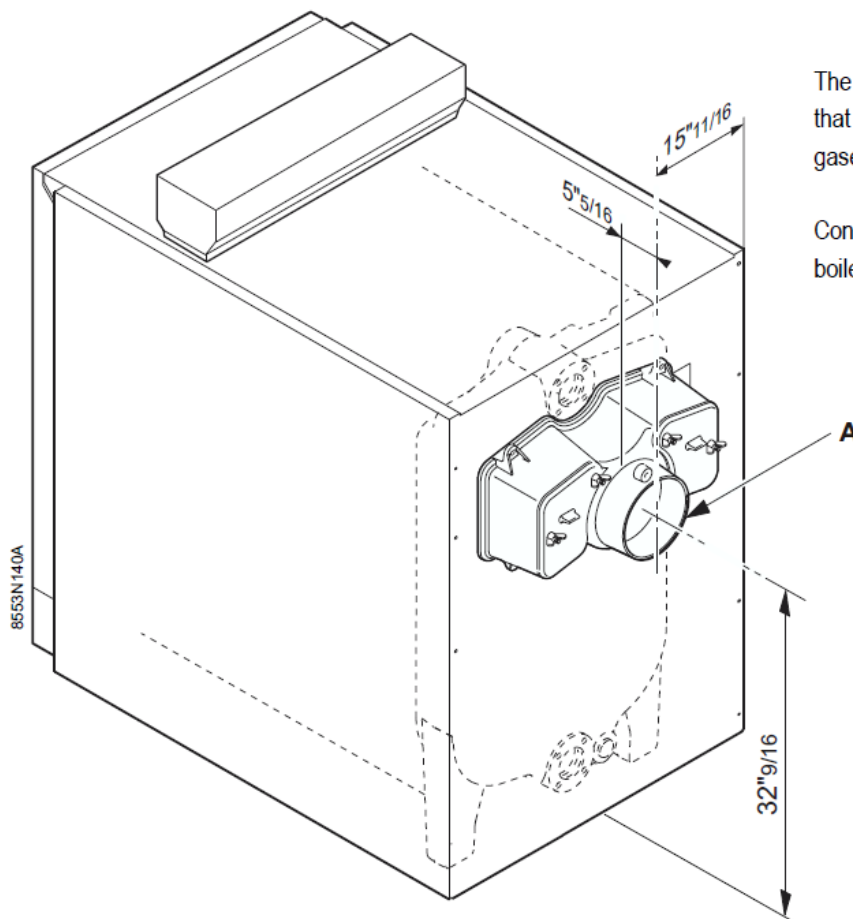

The boiler must be connected to venting system that will safely and effectively discharge all flue gases to the outside in an effective manner.

Consult local and national codes regarding the boiler breeching and chimney sizing.

A= chimney connection:

GT 334A to GT 336A: 7" \varnothing

GT 337A to GT 339A: 8" \varnothing

Oil or gas connections

1 Specific technical information supplied with the burner

- The boiler and its individual shutoff valve must be disconnected from the gas supply piping system during any pressure testing of that system at test pressures in excess of 1/2 psi (3.5 kPa),
- The boiler must be isolated from the gas supply piping system by closing its individual manual shutoff valve during any pressure testing of the gas supply piping system at test pressures equal to or less than 1/2 psi (3.5 kPa),
- The boiler shall be installed such that the gas ignition system components are protected from water (dripping, spraying, rain, etc.) during appliance operation and service (circulator replacement, condensate trap, control replacement, etc.),
- The boiler and its gas connection must be leak tested before placing the boiler in operation,
- After placing the boiler in operation, the ignition system safety shutoff device must be tested,
- Provision for vent, bleed and gas relief lines (when applicable),
- A sediment trap must be provided upstream of the gas controls,
- Location of manual main shutoff valve outside the jacket when codes require.

Follow the information and documentation as supplied with the burner, regarding:

The specific installation requirements, wiring, fuel supply and piping and all adjustments of the air and fuel and start-up procedure as be followed as supplied with the burner documentation

Consult the burner manufacturer regarding the required maintenance of the burner and the service intervals.

The entire heating system must be check once each heating season.

Do not start the burner/boiler unless all access cover and panels are in place.

Electrical

1 Wiring

Wiring in accordance with the requirements of the authority having jurisdiction or, in the absence of such requirements, with the Canadian Electrical Code Part 1, CSA C22.1, Electrical Codes.

Warning/Caution:
Label all wiring prior to disconnection for servicing controls. Wiring errors can cause improper and dangerous operation.

"Verify Proper Operation After Servicing"

2 Wiring procedure

De Dietrich boiler suggested field wiring procedure.

1 : Topview

2 : Boilerpanel

3 : Front

A : Race ways located under top panel of boiler

B : Wiring to be run in electrical race way to boiler control panel from ancillaries

Main power to 4x4 junction box or enter rear of boiler through race way.

C : 4x4 junction box location

D : Run BX cable between insulation and casing from boiler panel

E : Allow extra cable to swing burner open

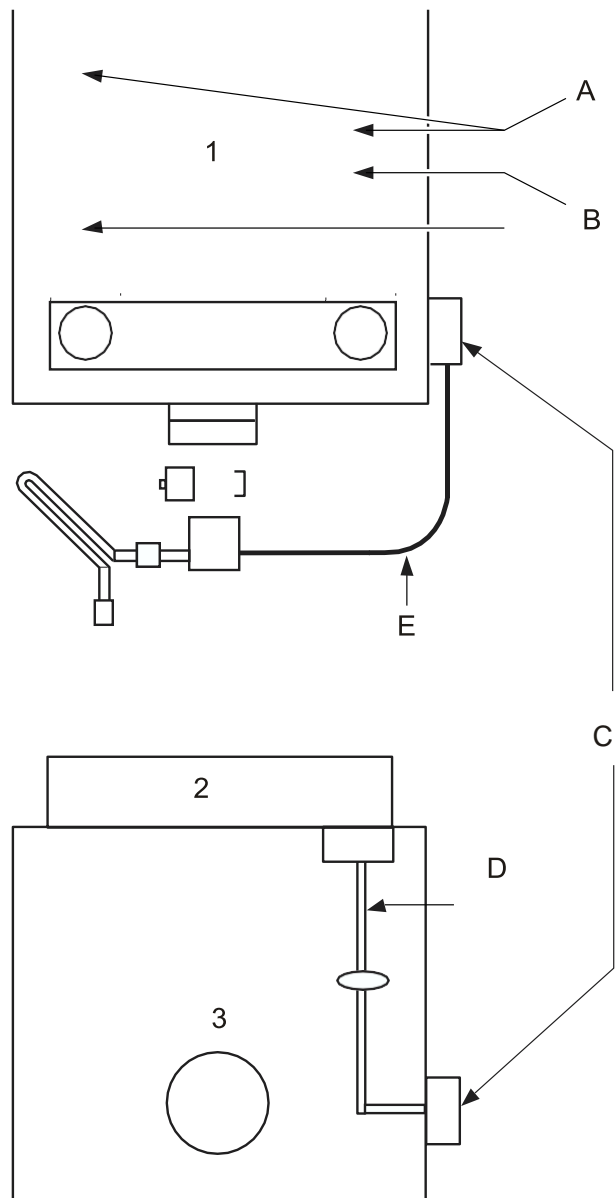

De Dietrich Cast Iron Boiler Temperature Controller Model S3NA (standard version) OVERVIEW OF COMPONENTS

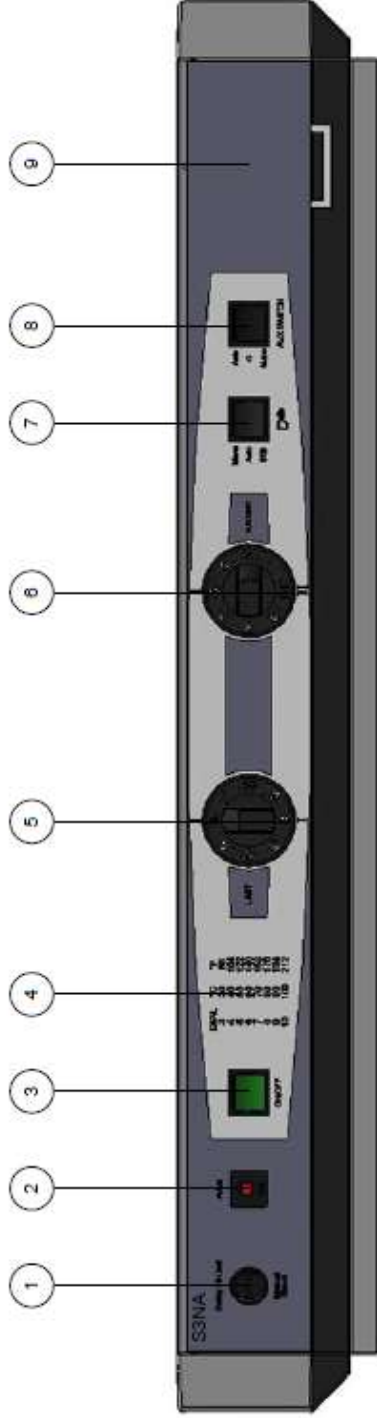

- ① Safety Hi-Limit (Manual Reset) Fixed Setting 120°C [248°F]
- ② Panel fuse protection (resettable-breaker) 250v 10A rated
- ③ Main ON/OFF Switch
- ④ Operating limits dial conversion
- ⑤ Limit adjustable 40-100°C [104-212°F]
- ⑥ Aux Limit adjustable 40-100°C [104-212°F] optional usage, for 2 stage control (L-H-L) or additional operating limit, additional relay required not provided
- ⑦ Man/Auto/STB 3 position operating switch:
Man = Local panel operation
Auto = Remote control operation – separate operating control required.
STB = Testing Safety limit function
- ⑧ Aux Switch – Optional usage (not part of safety circuit) consult factory for appropriate use and applications.
- ⑨ Provisional panel knockout for optional digital control offering (consult factory for availability)

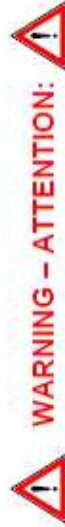

WARNING – ATTENTION:

All replacement and field wiring min 18awg. Type TEW or 1015 CSA/UL approved.

It is the sole responsibility of the installer/owner that the controls are operating correctly

Wiring mistake can lead to personal injury (including death) or property damage. Mark all wires when prior to servicing or replacing wires or components.

All water piping shall be arranged to avoid spray or ingestion of water on control

Do not operate control if ingested or damaged by water. Do not attempt to repair, lockout and tag equipment, replace control immediately.

Revisions		Description		Standard De Dietrich GT 330A-430A-530A Series cast iron boiler temperature controller S3NA Panel	
Date	Description	Initial	Craig H.	Tolerances ±	Material
				none	none
				Scale	File Name
				Units	Date [mm/dd/yy]
				2	4-343-S3V-001
				none	08/12/09

S2NA or S3NA Temperature control panel (Internal wiring by DDR-De Dietrich factory)

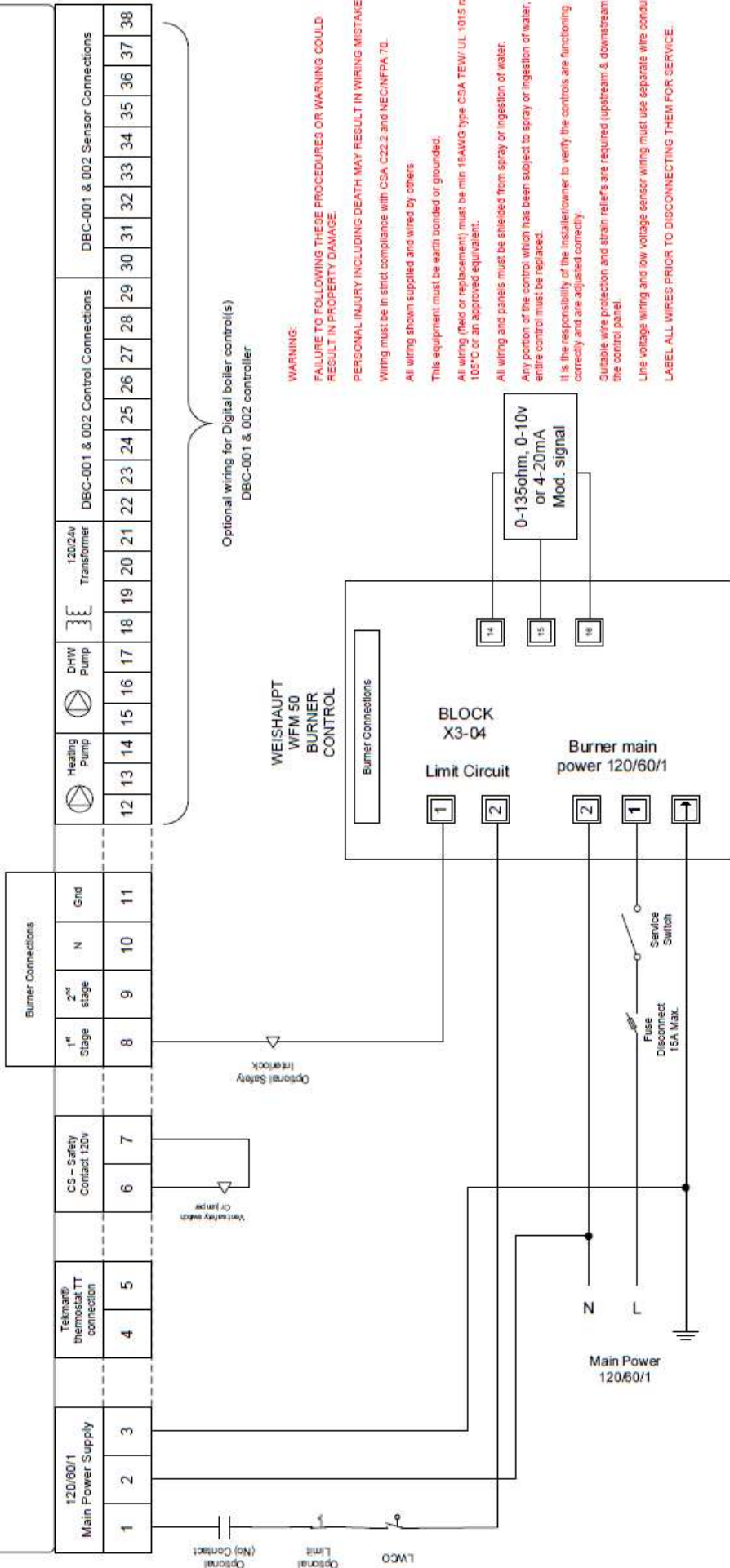

WARNING:
FAILURE TO FOLLOWING THESE PROCEDURES OR WARNING COULD RESULT IN PROPERTY DAMAGE.
PERSONAL INJURY INCLUDING DEATH MAY RESULT IN WIRING MISTAKES.
Wiring must be in strict compliance with CSA C22.2 and NEC/NFPA 70.
All wiring shown supplied and wired by others
This equipment must be earth bonded or grounded.
All wiring (if/ed or replacement) must be min 15AWG type CSA TEW UL 1015 rated 105°C or an approved equivalent.
All wiring and panels must be shielded from spray or ingestion of water.
Any portion of the control which has been subject to spray or ingestion of water, the entire control must be replaced.
It is the responsibility of the installer/owner to verify the controls are functioning correctly and are adjusted correctly.
Suitable wire protection and strain reliefs are required (upstream & downstream) of the control panel.
Line voltage wiring and low voltage sensor wiring must use separate wire conduits.
LABEL ALL WIRES PRIOR TO DISCONNECTING THEM FOR SERVICE.

All field wiring shown by others

- 1 Burner terminals
- 1 Boiler panel terminals

**S2NA OR S3NA
PANEL APPLICATION WIRING
FULL MODULATING OPERATION**

Drawn by: CJH 10-22-08 DWG #: 4-GTB-S23-005 (Rev0)



S2NA or S3NA Temperature control panel (Internal wiring by DDR-De Dietrich factory)

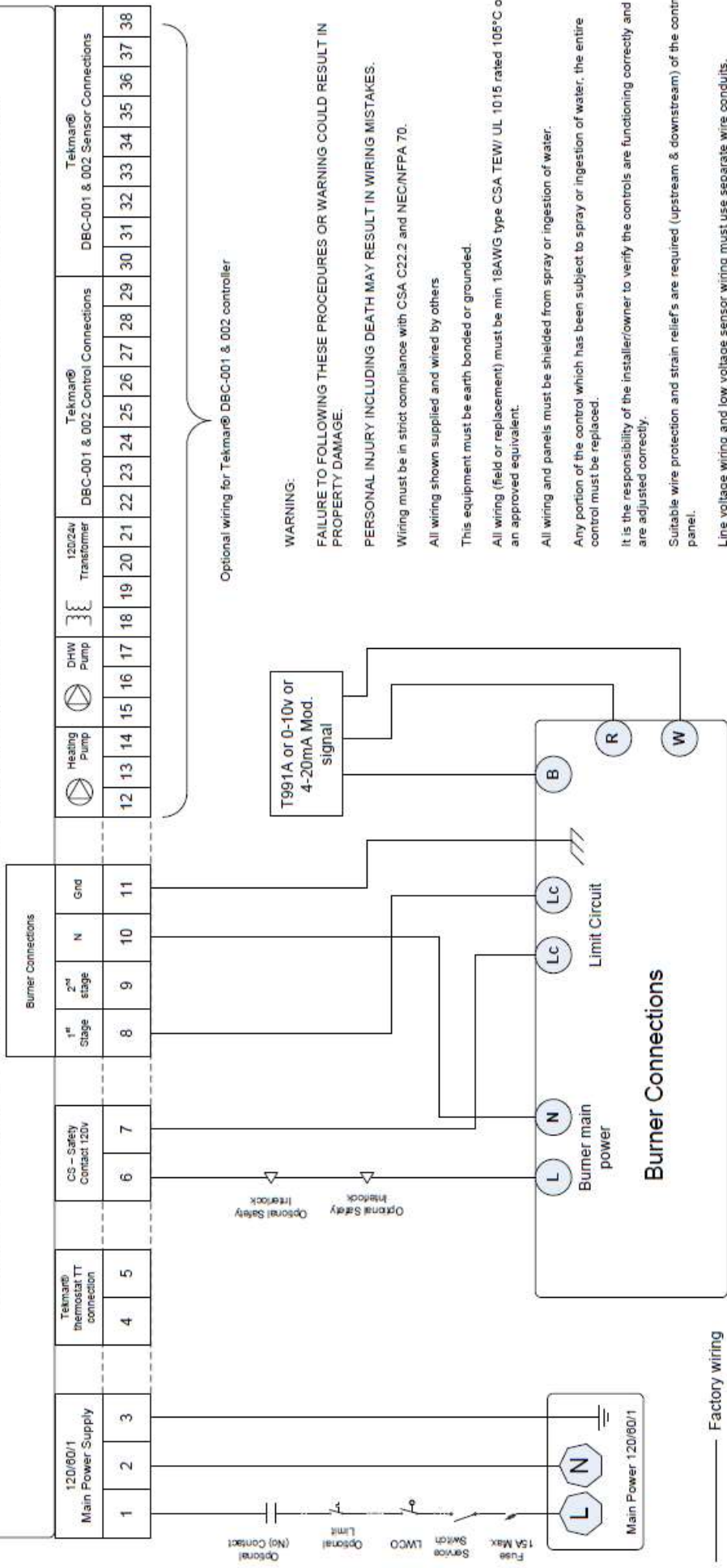

Optional wiring for Tekmar® DBC-001 & 002 controller

WARNING:
FAILURE TO FOLLOWING THESE PROCEDURES OR WARNING COULD RESULT IN PROPERTY DAMAGE.
PERSONAL INJURY INCLUDING DEATH MAY RESULT IN WIRING MISTAKES.
Wiring must be in strict compliance with CSA C22.2 and NEC/NFPA 70.

All wiring shown supplied and wired by others
This equipment must be earth bonded or grounded.
All wiring (field or replacement) must be min 18AWG type CSA TEW/UL 1015 rated 105°C or an approved equivalent.
All wiring and panels must be shielded from spray or ingestion of water.

Any portion of the control which has been subject to spray or ingestion of water, the entire control must be replaced.
It is the responsibility of the installer/owner to verify the controls are functioning correctly and are adjusted correctly.
Suitable wire protection and strain reliefs are required (upstream & downstream) of the control panel.
Line voltage wiring and low voltage sensor wiring must use separate wire conduits.
LABEL ALL WIRES PRIOR TO DISCONNECTING THEM FOR SERVICE.

— Factory wiring
- - - Field wiring (By Others)

Drawn by: C:JH 06-24-08 DWG #: 4-GTB-S23-004 (Rev0)



**S2NA OR S3NA
PANEL APPLICATION WIRING
FULL MODULATING OPERATION**

S2NA (ME50) or S3NA (MD5) Temperature control panel (Internal wiring by DDR-De Dietrich factory)

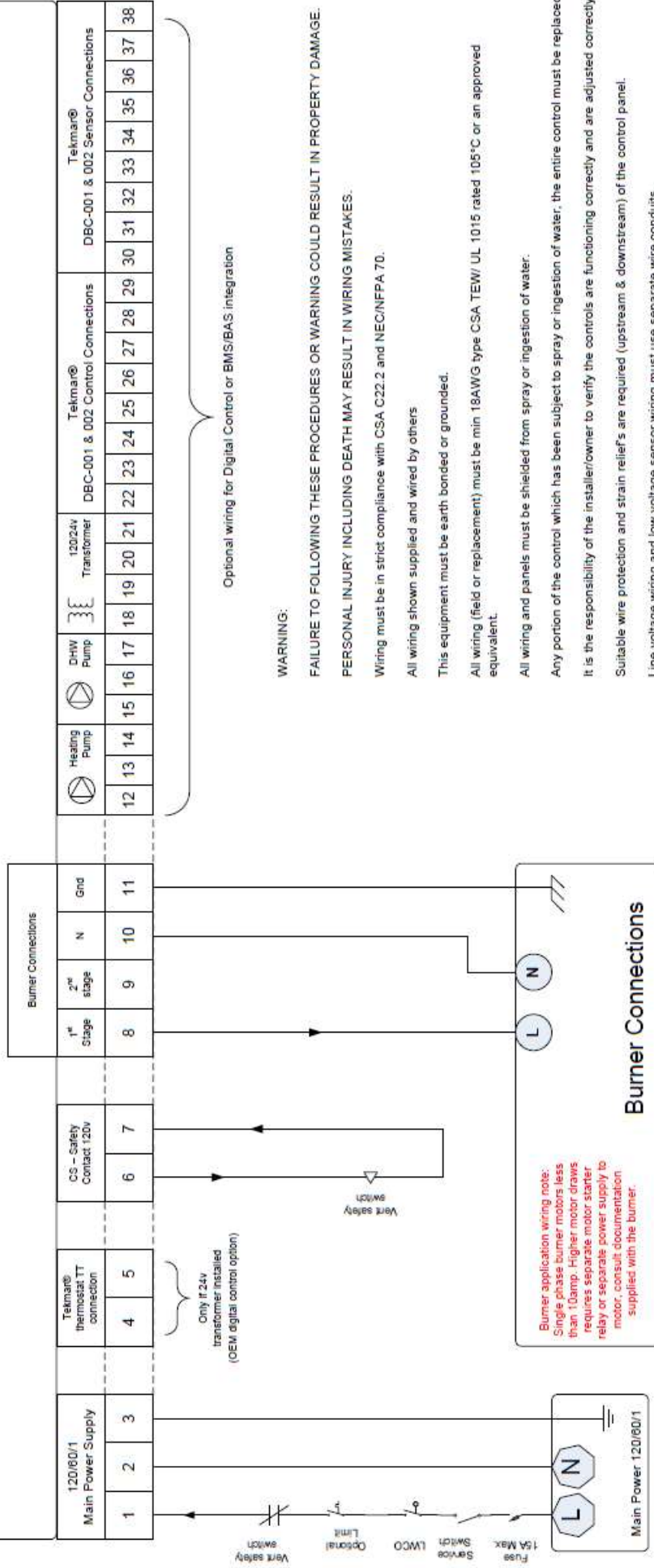

**DE DIETRICH BOILER CONTROL
PANELS: S2NA & S3NA**

**PANEL APPLICATION WIRING
ON/OFF (SINGLE STAGE) OPERATION**

Drawn by: CJH 11-05-08 DWG #: 4-GTB-S23-010 (Rev0)



S2NA (ME50) or S3NA (MD5) Temperature control panel (FIELD WIRING DIAGRAM)

Internal wiring by DDR-De Dietrich factory

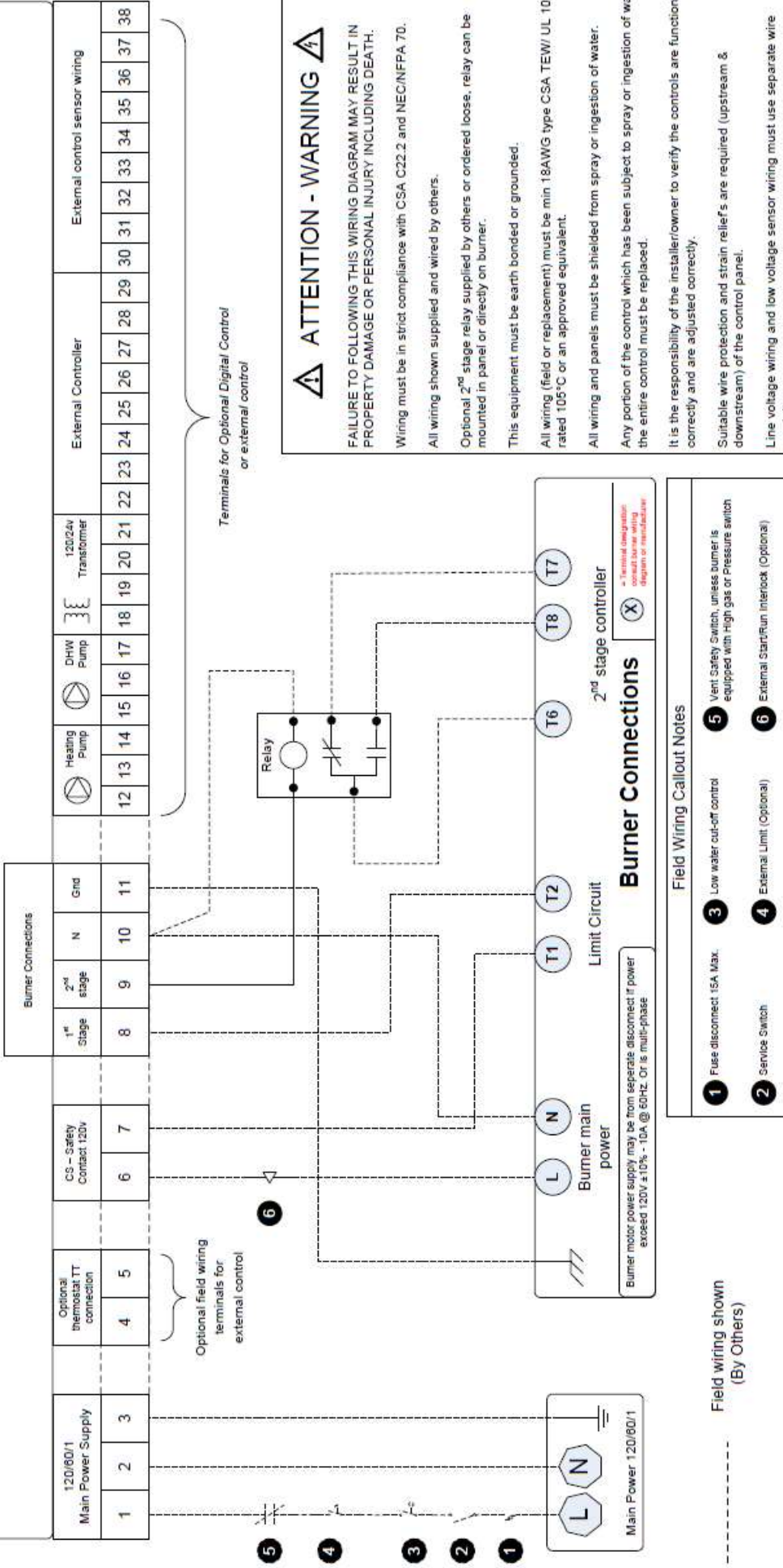

⚠ ATTENTION - WARNING ⚠

FAILURE TO FOLLOWING THIS WIRING DIAGRAM MAY RESULT IN PROPERTY DAMAGE OR PERSONAL INJURY INCLUDING DEATH.

Wiring must be in strict compliance with CSA C22.2 and NEC/NFPA 70.

All wiring shown supplied and wired by others.

Optional 2nd stage relay supplied by others or ordered loose, relay can be mounted in panel or directly on burner.

This equipment must be earth bonded or grounded.

All wiring (field or replacement) must be min 18AWG type CSA TEW/UL 1015 rated 105°C or an approved equivalent.

All wiring and panels must be shielded from spray or ingestion of water.

Any portion of the control which has been subject to spray or ingestion of water, the entire control must be replaced.

It is the responsibility of the installer/owner to verify the controls are functioning correctly and are adjusted correctly.

Suitable wire protection and strain reliefs are required (upstream & downstream) of the control panel.

Line voltage wiring and low voltage sensor wiring must use separate wire conduits.

LABEL ALL WIRES PRIOR TO DISCONNECTING THEM FOR SERVICE.

Drawn by: CJH 08-06-09 DWG #: 4-GTB-S23-002 (Rev1)



RIELLO OR WIESHAUPT BURNER
TYPICAL PANEL WIRING APPLICATION
2-STAGE (L-H-L) OPERATION

S2NA (ME50) or S3NA (MD5) Temperature control panel (FIELD WIRING DIAGRAM)

Internal wiring by DDR-De Dietrich factory

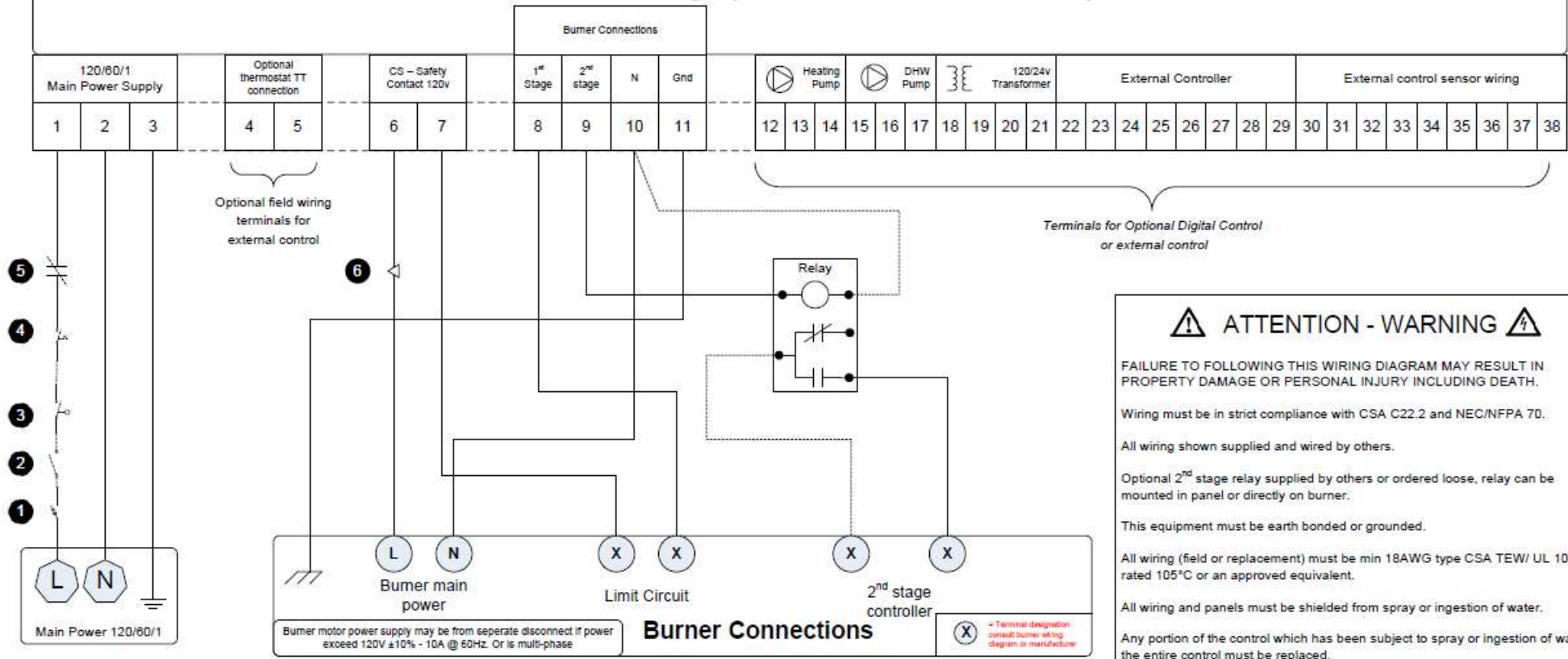

Burner motor power supply may be from separate disconnect if power exceed 120V ±10% - 10A @ 60HZ. Or is multi-phase

Burner Connections

(X) = Terminal designation consult burner wiring diagram or manufacture

- Field Wiring Callout Notes**
- 1 Fuse disconnect 15A Max.
 - 3 Low water out-off control
 - 5 Vent Safety Switch, unless burner is equipped with High gas or Pressure switch
 - 2 Service Switch
 - 4 External Limit (Optional)
 - 6 External Start/Run Interlock (Optional)

⚠ ATTENTION - WARNING ⚠

FAILURE TO FOLLOWING THIS WIRING DIAGRAM MAY RESULT IN PROPERTY DAMAGE OR PERSONAL INJURY INCLUDING DEATH.

Wiring must be in strict compliance with CSA C22.2 and NEC/NFPA 70.

All wiring shown supplied and wired by others.

Optional 2nd stage relay supplied by others or ordered loose, relay can be mounted in panel or directly on burner.

This equipment must be earth bonded or grounded.

All wiring (field or replacement) must be min 18AWG type CSA TEW/ UL 1015 rated 105°C or an approved equivalent.

All wiring and panels must be shielded from spray or ingestion of water.

Any portion of the control which has been subject to spray or ingestion of water, the entire control must be replaced.

It is the responsibility of the installer/owner to verify the controls are functioning correctly and are adjusted correctly.

Suitable wire protection and strain reliefs are required (upstream & downstream) of the control panel.

Line voltage wiring and low voltage sensor wiring must use separate wire conduits.

LABEL ALL WIRES PRIOR TO DISCONNECTING THEM FOR SERVICE.

Drawn by: CJH 08-06-09 DWG #: 4-GTB-S23-001 (Rev1)



TYPICAL PANEL WIRING APPLICATION 2-STAGE (L-H-L) OPERATION

FOR YOUR SAFETY READ BEFORE OPERATING



WARNING: If you do not follow these instructions exactly a fire or explosion may result causing property damage personal injury or loss of life.

A. This appliance does not have a pilot. It is equipped with an ignition device which automatically lights the burner. Do not try to light the burner by hand.

B. BEFORE OPERATING smell all around the appliance area for gas. Be sure to smell next to the floor because some gas is heavier than air and will settle on the floor.

WHAT TO DO IF YOU SMELL GAS

- Do not try to light any appliance.
- Do not touch any electric switch; do not use any phone in your building.
- Immediately call your gas supplier from a neighbor's phone. Follow the gas supplier's instructions.
- If you cannot reach your gas supplier, call the fire department.

C. Use only your hand to push in or turn the gas control knob. Never use tools. If the knob will not push in or turn by hand, don't try to repair it: call a qualified service technician. Force or attempted repair may result in a fire or explosion.

D. Do not use this appliance if any part has been under water. Immediately call a qualified technician to inspect the appliance and to replace any part of the control system and any gas control which has been under water.

1 Start-up procedures

- Inspect for proper baffling insertion into flue passes. All clean-out doors properly sealed. Burner door closed and properly latched.
- Gas and oil systems ready. Proper vent connections. Required combustion and ventilation air provided.
- Waterside of system properly filled and vented of air.
- Lighting instruction followed.

- To be performed by a licensed tradesperson in accordance with the guidelines shown in this manual. Follow burner manufactures instructions.
- Mandatory factory start-up report to be completed and returned to comply with the warranty process.
- Proper operating instructions of equipment to be related to operating personnel.

2 Shut-down procedures

- Disengage all electrical power switches to heating system burners, pumps. Isolate all boiler valves and fuel valves.
- For off-season shutdown, open boiler combustion flue ways and clean. Ensure venting, chimney, combustion and ventilation air openings free from blockage. Do not drain waterside of system.
- Shutoff fuel supply lines

Maintenance

1 Boiler

It is not advisable to drain an installation, except in case of absolute necessity. Check the water level of the installation and top it off if necessary, avoiding a sudden inlet of cold water in the hot boiler.

Check for system leaks.

- **Cleaning of the flue gas circuit :**
 - switch off the electricity supply to the boiler
 - unhook the front cover

Professional water treatment is recommended.

The good performance of the boiler depends on cleanliness.

Cleaning the boiler must be carried out as often as required and at least, as for the flue once a year. The following operations are always carried out with the boiler and the power supply shut off.

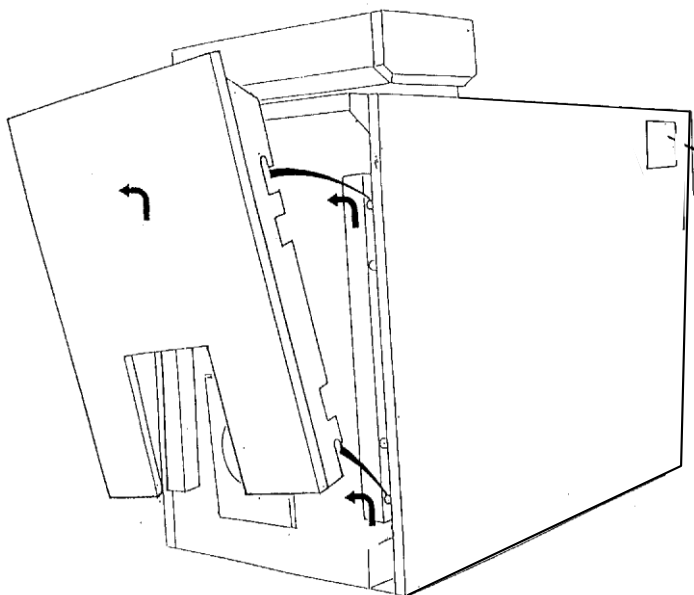

Ensure all access cover and doors are in place prior to starting the boiler-burner.

- open the sweeping door (upper door) by unscrewing the 4 lock nuts.
- remove the convection baffles,
- using the brush supplied, carefully sweep the 6 flue sections,

- also brush the convection baffles and the front face,
- if possible use a vacuum cleaner,
- put the convection accelerators back in place (pay attention to their direction),
- shut the door.

• **Maintenance of the combustion chamber**

- open the combustion chamber door (lower door) by unscrewing the 4 locknuts
- brush the inside of the combustion chamber

- using a vacuum cleaner, vacuum up the soot deposits which have accumulated in the combustion chamber
- close the door and replace the front cover

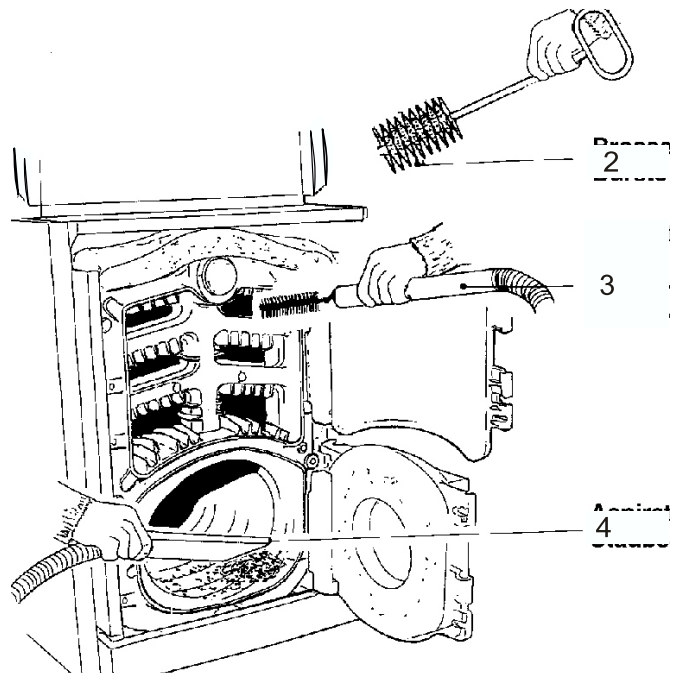
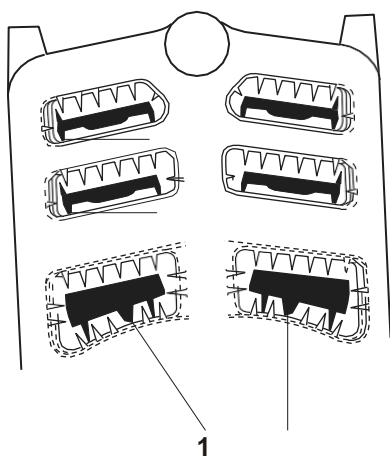

1: stop pins

3 : vacuum cleaner brush

2: brush

4 : vacuum cleaner

Baffle Position	Baffle	Fraction	mm	GT 334 A	GT 335 A	GT 336 A	GT 337 A	GT 338 A	GT 339 A
Upper [3rd Pass]	8219-0017	16 1/4	410	0	8	8	4	0	0
Middle [2nd Pass]	8219-0018	22 7/16	570	4	0	0	4	8	8
Lower [1st Pass]	8219-0019	16 1/4	412	2	2	2	2	4	2
	8219-0020	22 1/2	572	0	0	0	0	0	2

• **Cleaning the smoke box (Flue Hood)**

For this purpose:

-remove the sweeping left and right hand covers of the smoke box (2 wing nuts) and remove the soot which has accumulated using a vacuum cleaner

-replace the sweeping covers.

• **Burner maintenance :**

In accordance with the directions supplied with the burner.

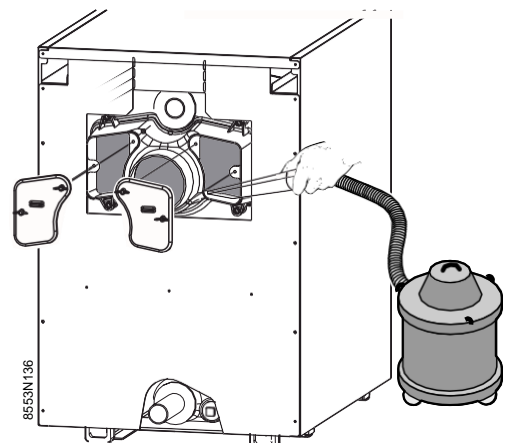

Service and maintenance schedule

- Require annual system inspection of the heating boiler, burner and controls by qualified service personnel,
- Heating system check for safety control functions, system pressure, leaks, combustion and ventilation air should be done on a monthly schedule.

Extended Shutdown Periods

If the system is to be shutdown for any extended period of time, please follow these steps:

1. Shut off all pumps
2. Cap off venting of boiler at the boiler collars
3. Shut off supply & Return Valves
4. Shut off the fuel supply valves
5. Disconnect power at the panel
6. Clean boiler and venting

Boiler general piping diagram and safety components

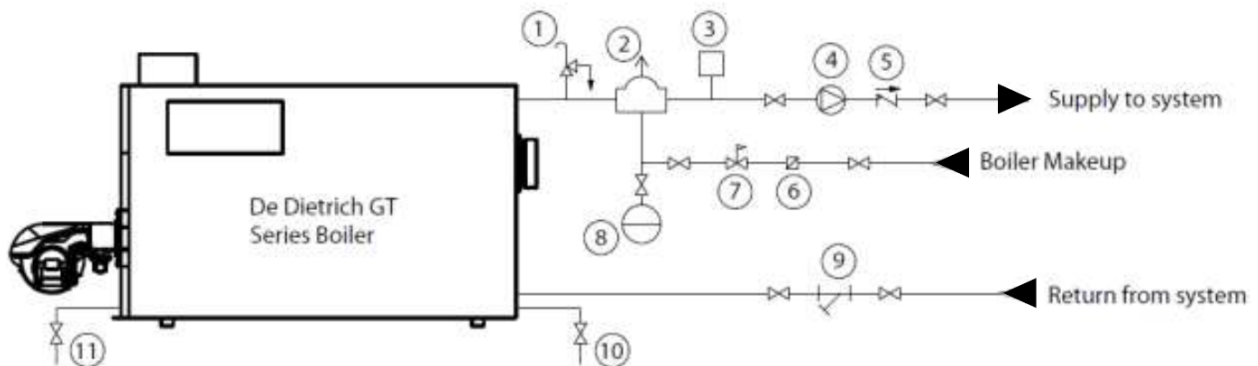

- | | |
|---|----------------------------------|
| ① ASME rated pressure relief valve | ⑦ Pressure regulating valve |
| ② Air separator with automatic air vent | ⑧ Diaphragm style expansion tank |
| ③ Low water cut off | ⑨ Strainer |
| ④ Circulating Pump | ⑩ Drain valve |
| ⑤ Flow check valve | ⑪ Sludge removal flush valve |
| ⑥ Back flow preventer | |

Spare parts - GT 330 A

06/10/06 - 8553-4312B



While ordering spare parts, do not forget to provide the code number given opposite the part reference.

BOILER BODY AND ACCESSORIES

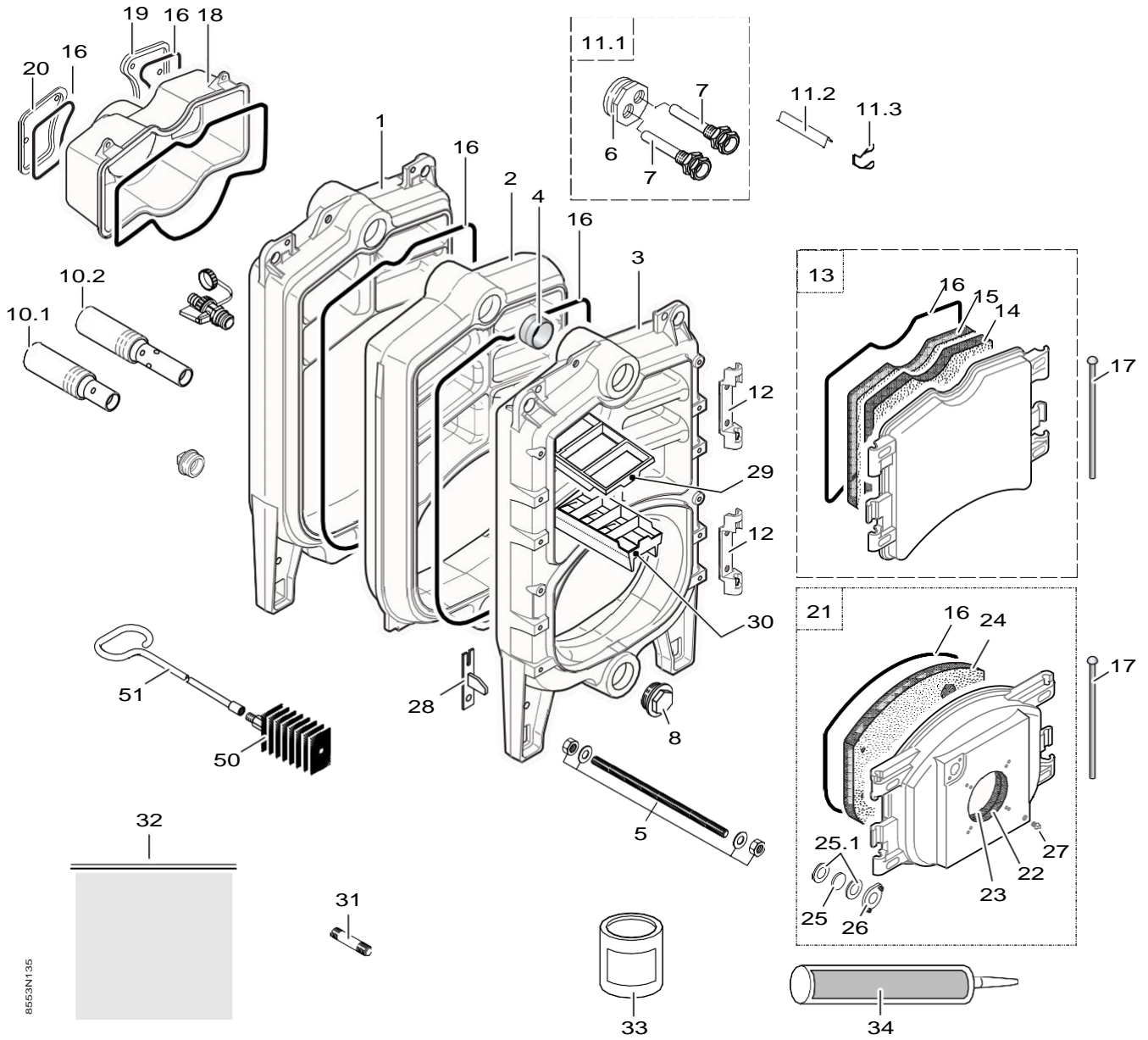

8553N135

BASE FRAME + INSULATION

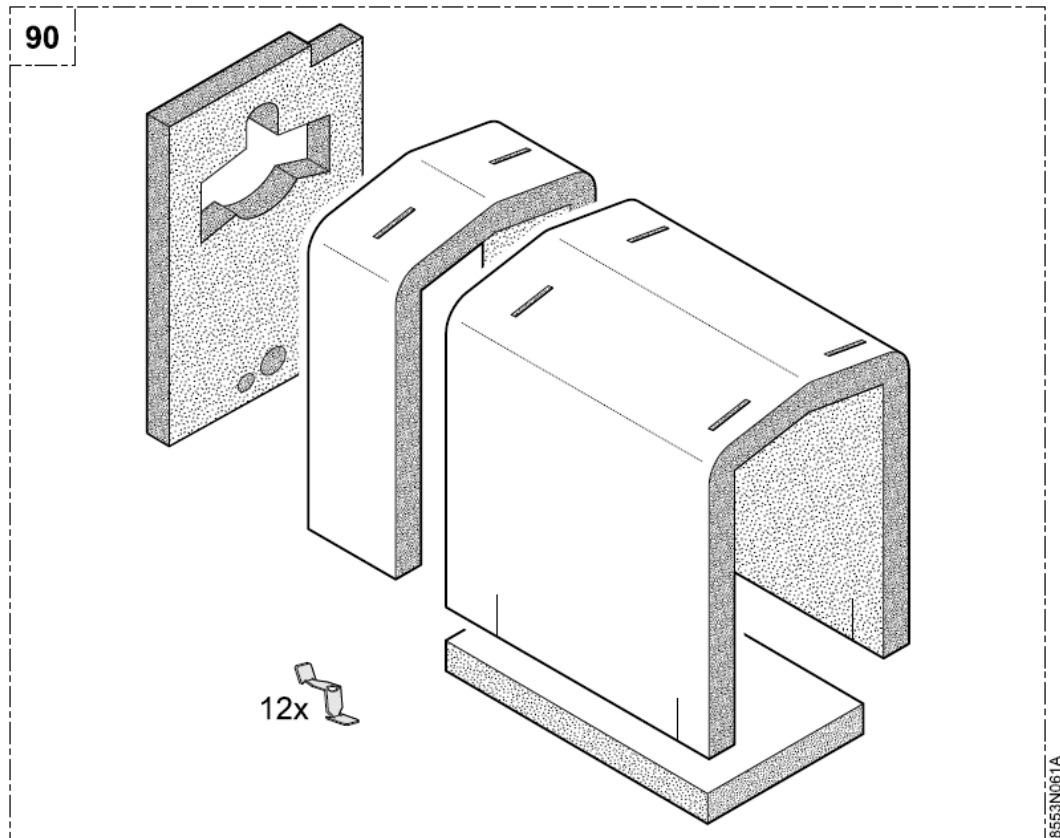
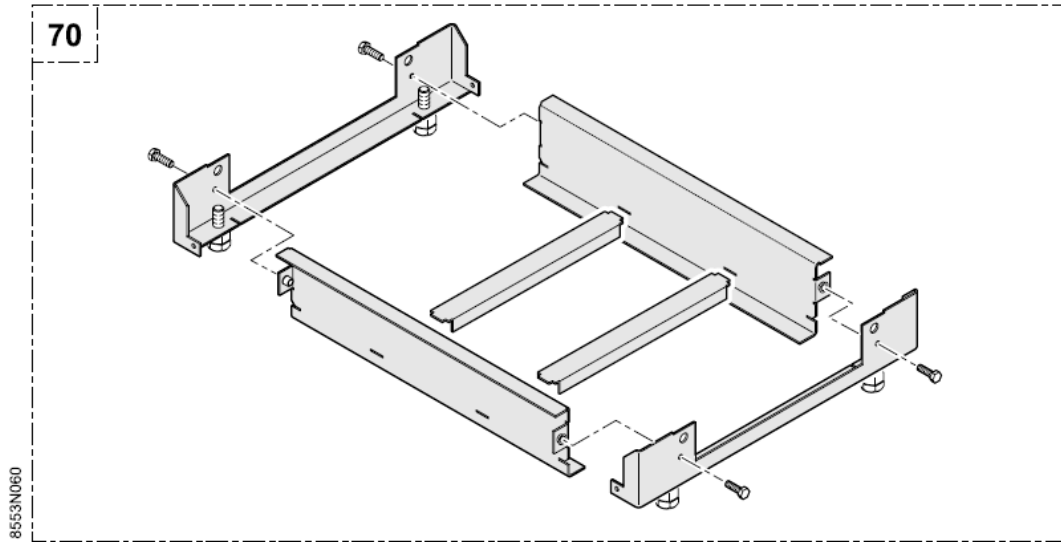

CASING

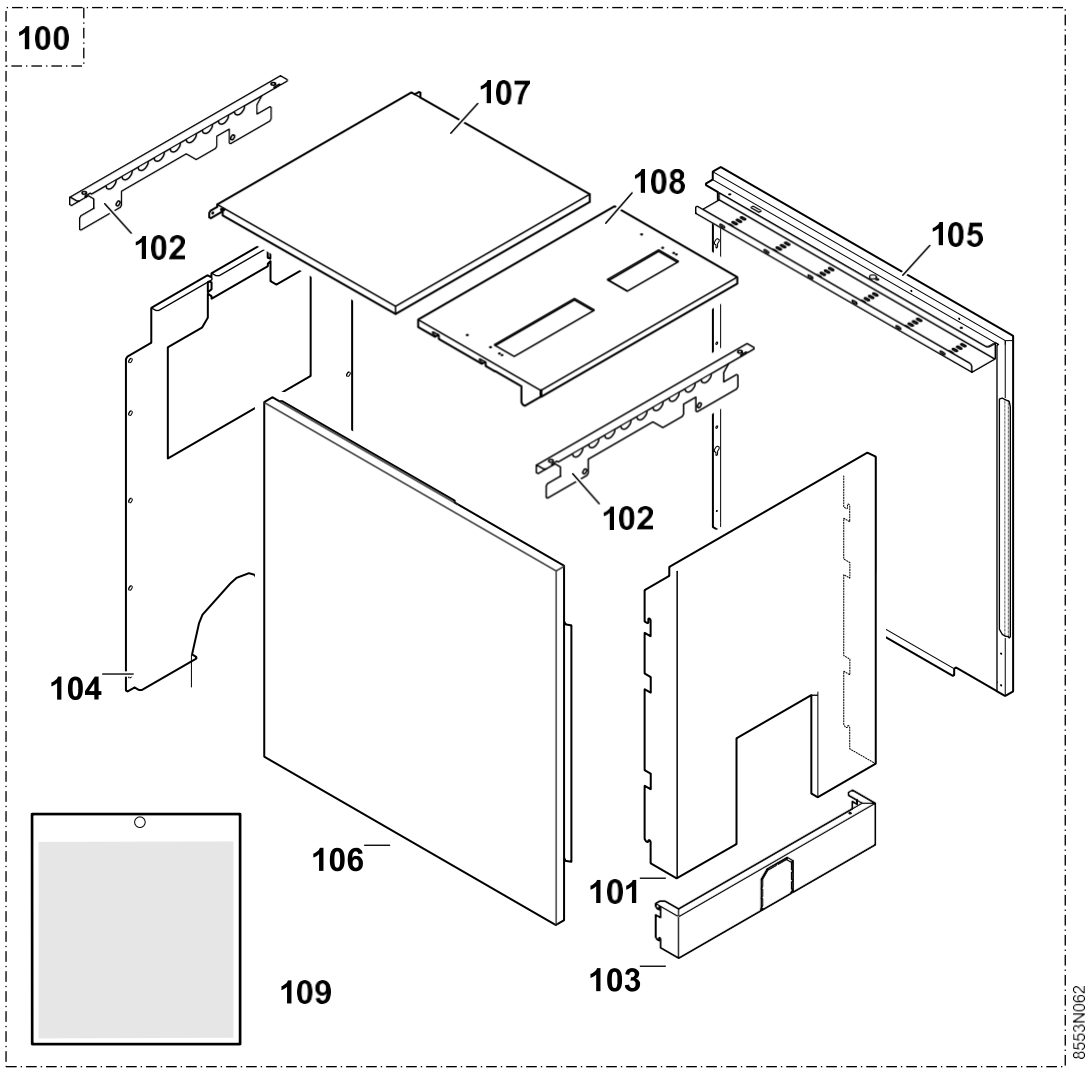

Ref.	Code no.	DESCRIPTION
BOILER BODY		
1	8219-0032	Complete rear section
2	8219-8966	Complete intermediate section
3	8219-8976	Complete front section
4	8116-0571	Nipple
5	8219-8944	Complete 4 section assembly rod
5	8219-8945	Complete 5 section assembly rod
5	8219-8946	Complete 6 section assembly rod
5	8219-8947	Complete 7 section assembly rod
5	8219-8948	Complete 8 section assembly rod
5	8219-8949	Complete 9 section assembly rod
6	8209-0049	2 ^{1/2} " plug with 2 holes
7	9536-5611	Well
8	8209-0048	Plain plug
10.1	9754-9934	Water balancing tube GT 306 A to GT 308 A
10.2	9754-9935	Water balancing tube GT 309 A
11.1	8209-8948	2 ^{1/2} " plug with 2 holes + well
11.2	9536-5613	Separator for well
11.3	9758-1286	Spring for well
12	8104-8984	Hinge
13	8219-8916	Complete cleaning door
14	9425-0306	Internal cleaning door insulation
15	9425-0305	External cleaning door insulation
16	9508-6032	Ø 10 thermocord
17	9756-0203	Pin for hinge
18	8219-8913	Complete nozzle Ø 180 - 4 to 6 sections
18	8219-8914	Complete nozzle Ø 200 - 7 to 9 sections
19	8219-0206	Right nozzle plug
20	8219-0207	Left nozzle plug
21	8219-7718	Complete burner door - BP13 - burner hole Ø 135 mm
21	8219-7020	Complete burner door - BP114 burner hole Ø 190 mm
22	9425-0303	Internal burner door protection
23	9425-0302	Intermediate burner door protection
24	9425-0301	External burner door insulation
25	9500-6017	Glass for inspection window
25.1	9501-0080	Gaskets for inspection window
26	9757-0027	Inspection flange
27	9495-0050	1/4" plug
28	8219-0539	Guide flap for burner door
29	8219-0017	Upper baffles length 410 mm
29	8219-0018	Upper baffles length 570 mm
30	8219-0019	Lower baffles length 412 mm
30	8219-0020	Lower baffles length 572 mm
31	9601-0107	M8-60/52 studs

DESCRIPTION		
31	9601-0260	M12x33/26 studs
31	9601-0302	M12x61/57 studs
32	8219-8957	Bag of screws for boiler body
33	9430-5027	Putty for nipples
34	9428-5095	Silicone putty tube
MISCELLANEOUS		
50	9750-5025	Brush
51	9750-5076	Brush rod length 1000 mm
51	9750-5060	Brush rod length 1300 mm
BASE FRAME		
70	8553-7060	Complete base frame, 4 sections - package FD 30
70	8553-7061	Complete base frame, 5 sections - package FD 31
70	8553-7062	Complete base frame, 6 sections - package FD 32
70	8553-7063	Complete base frame, 7 sections - package FD 33
70	8553-7064	Complete base frame, 8 sections - package FD 34
70	8553-7065	Complete base frame, 9 sections - package FD 35
INSULATING MATERIAL		
90	8553-5507	Complete boiler body insulation, 4 sections
90	8553-5508	Complete boiler body insulation, 5 sections
90	8553-5509	Complete boiler body insulation, 6 sections
90	8553-5510	Complete boiler body insulation, 7 sections
90	8553-5511	Complete boiler body insulation, 8 sections
90	8553-5512	Complete boiler body insulation, 9 sections
CASING		
100	8553-5500	Complete casing, 4 sections
100	8553-5501	Complete casing, 5 sections
100	8553-5502	Complete casing, 6 sections
100	8553-5503	Complete casing, 7 sections
100	8553-5504	Complete casing, 8 sections
100	8553-5505	Complete casing, 9 sections
101	8219-1000	Insulated front panel
102	8553-8000	Upper fastening bracket
103	8553-5506	Insulated lower cover
104	8553-8519	Complete rear panel
105	8553-8500	Right-hand side panel, 4 sections
105	8553-8501	Right-hand side panel, 5 sections
105	8553-8502	Right-hand side panel, 6 sections
105	8553-8503	Right-hand side panel, 7 sections
105	8553-8504	Right-hand side panel, 8 sections
105	8553-8505	Right-hand side panel, 9 sections
106	8553-8506	Left-hand side panel, 4 sections

Ref.	Code no.	DESCRIPTION
106	8553-8507	Left-hand side panel, 5 sections
106	8553-8508	Left-hand side panel, 6 sections
106	8553-8509	Left-hand side panel, 7 sections
106	8553-8510	Left-hand side panel, 8 sections
106	8553-8511	Left-hand side panel, 9 sections
107	8553-8512	Rear cover, 4 sections
107	8553-8513	Rear cover, 5 sections
107	8553-8514	Rear cover, 6 sections
107	8553-8515	Rear cover, 7 sections
107	8553-8516	Rear cover, 8 sections
107	8553-8517	Rear cover, 9 sections
108	8553-8518	Complete front cover
109	8553-8520	Bag of casing fasteners

CONTROL PANEL

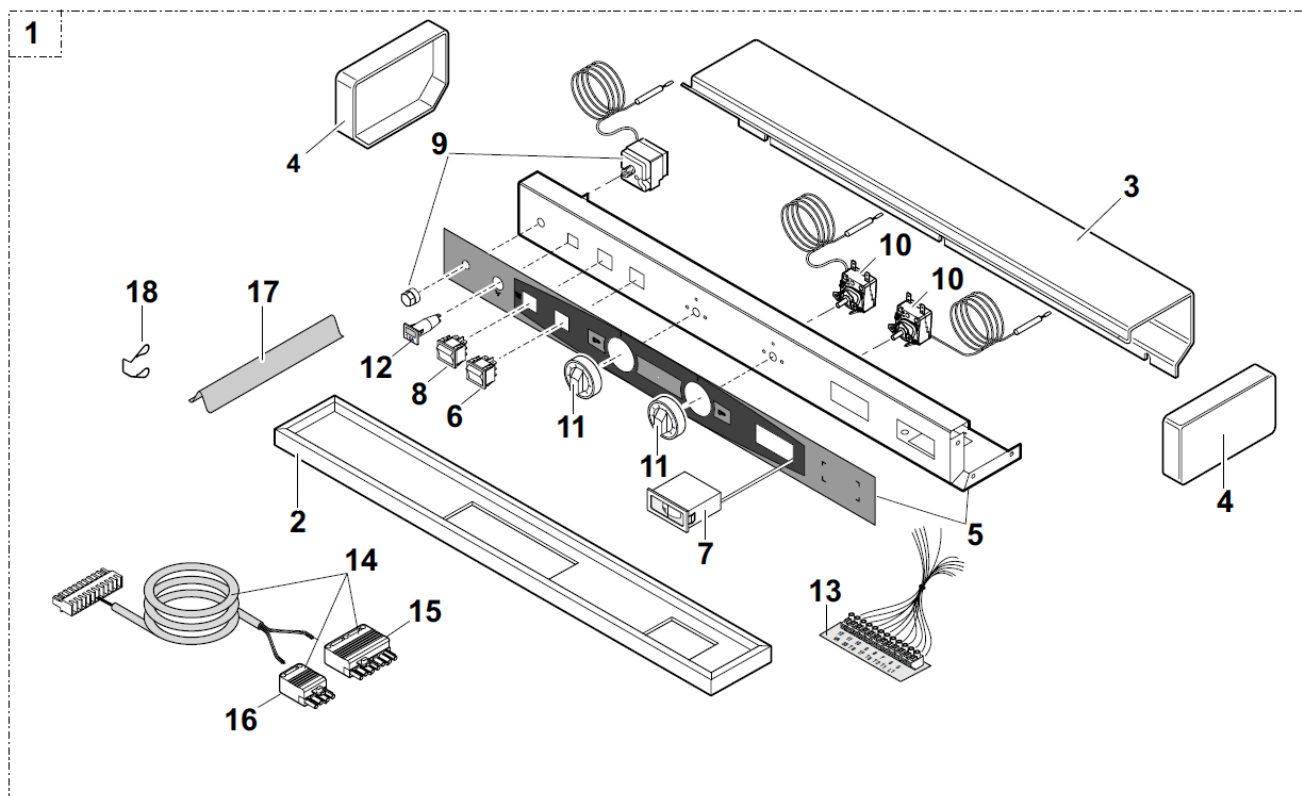

M000487

Ref	Code No	CONTROL PANEL Parts Description (S3NA MD)
1	100004299	Standard complete control panel
2	8219-0508	Painted control panel base
3	8557-0505	Cover
4	300007160	Side plate
5	200005221	Plastic coated panel
6	9532-5027	Green S/S bipolar switch
7	9536-5161	Thermometer
8	9532-5092	Bipolar switch
9	9536-3314	110 °C safety thermostat
10	9536-3364	30 to 90 °C setting thermostat
11	8555-5501	Setting button + Pin
12	9534-0286	Timed circuit breaker (10 A)
13	200005244	Standard beam
14	8219-4905	Electric circuit
15	9531-7395	7-pin plug
16	9531-7384	4-pin plug
17	9536-5613	Contact spring for pocket
18	9758-1286	Spring for pocket

Fuel oil/gas-fired boilers

GT 330



Assembly Instructions



Installation codes

The boiler shall be assembled and installed by a qualified professional only. Strict compliance with these installation and operating instructions is a precondition for the correct and guarantee of the boiler.

The installation must conform to the requirements of the authority having jurisdiction or, in the absence of such requirements, to the CAN/CGA B-149 fuel gas installation codes and CSA B-139 oil installation codes.

Where required by the authority having jurisdiction, the installation must conform to the standard for controls and safety devices for automatically fired boilers ANSI/ASME CSD-1.

The installation of the relief valve shall be consistent with ANSI/ASME boiler pressure vessel code, section 1V CSA B51.

The boiler must not be installed on carpeting.

If an external electrical source is utilized, the boiler when installed, must be electrically bonded to ground in accordance with the requirements of the authority having jurisdiction or, in the absence of such requirements, with the canadian electrical code part 1.CSA C22.1 electrical code.



Label all wires prior to disconnection when servicing controls. Wiring can cause improper operation after servicings. Verify proper operation after service.

Packing GT 330

For USA and Canada

1 Package list

i Refer to the applicable price list for any optional features used.

Package list : Before starting to assemble the boiler, refer to the table below to check if you have received all the packages required.

1. Boiler body + Accessories

■ Boilers supplied with an assembled body

Number of sections	4	5	6	7	8	9
Assembled boiler body (contents depend upon model)	Consult Factory for fully assembled boiler package.					

■ For boiler supplied with the boiler body in bulk

Number of sections	4	5	6	7	8	9
Front section	Package 8219-0002	1	1	1	1	1
Intermediate section	Package 8219-0001	2	3	4	5	6
Rear section	Package 8553-7072	1	1	1	1	1
Set of assembly rods		1	1	1	1	1
Accessories for body in bulk	1 Package	FD 127	FD 128	FD 129	FD 130	FD 131
Base frame	1 Package	FD 30	FD 31	FD 32	FD 33	FD 34

2. Burner door

Number of sections	4	5	6	7	8	9
Burner door	1 Package	BP 13	BP 13	BP 13	BP 13	BP 13

3. Baffle plates

Number of sections	4	5	6	7	8	9
Baffle plates	1 Package	BP 16	BP 17	BP 17	BP 19	BP 20

4. Casing

Number of sections	4	5	6	7	8	9
Casing	1 Package	MD7	MD8	MD9	MD10	MD11
Front panel	1 Package	MD162	MD162	MD162	MD162	MD162

5. Technical documents

Number of sections	4	5	6	7	8	9
1 Package (Content depends upon country)	1	1	1	1	1	1

6. Control panel

All models can be equipped with one of the following control panels:

Number of sections	4	5	6	7	8	9
Standard Panel S3NA	MD5	MD5	MD5	MD5	MD5	MD5
Control panel						

Assembly GT 330

Tools required



- Tube of silicon caulk
- Side cutter (for cutting thermocord)
- Wire brush (for cleaning section openings): use of a *1" fitting brush attached to cordless saves time.
- Sand cloth (for cleaning nipples): Using a power brush saves time.
- Solvent
- Wooden or rubber mallet
- Tightness sealant: See step 28

THESE TOOLS ARE IN ADDITION TO YOUR NORMAL TOOL REQUIREMENTS.

 some spare screws are provided.

 **Warning** : the order of assembly is given by the numbers of the various figures.

Symbols used

	Caution danger	Risk of injury and damage to equipment. Attention must be paid to the warnings on safety of persons and equipment
	Specific information	Information must be kept in mind to maintain comfort
	Reference	Refer to another manual or other pages in this instruction manual

1

FD30 - FD31 - FD32 - FD33 - FD34 - FD35

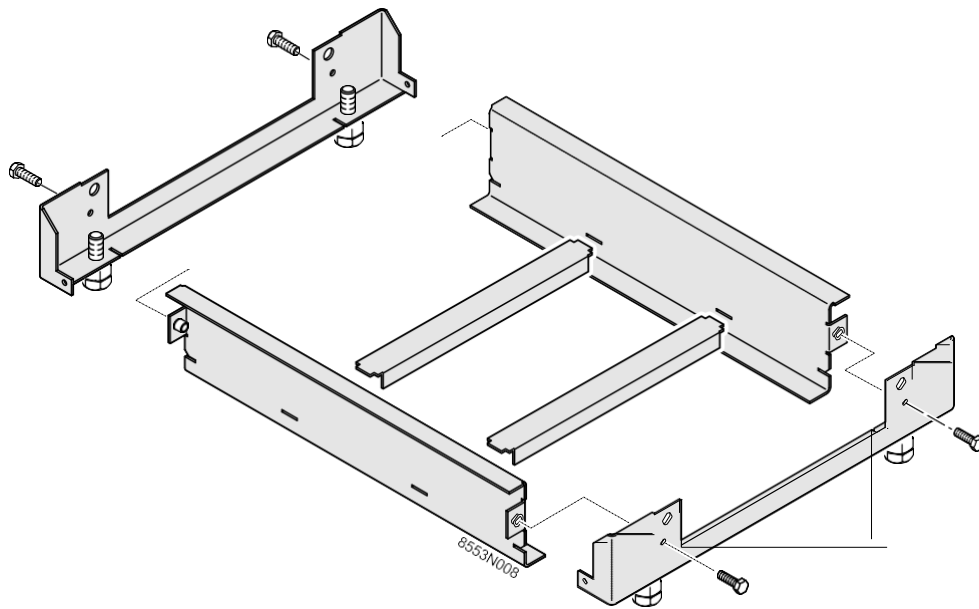
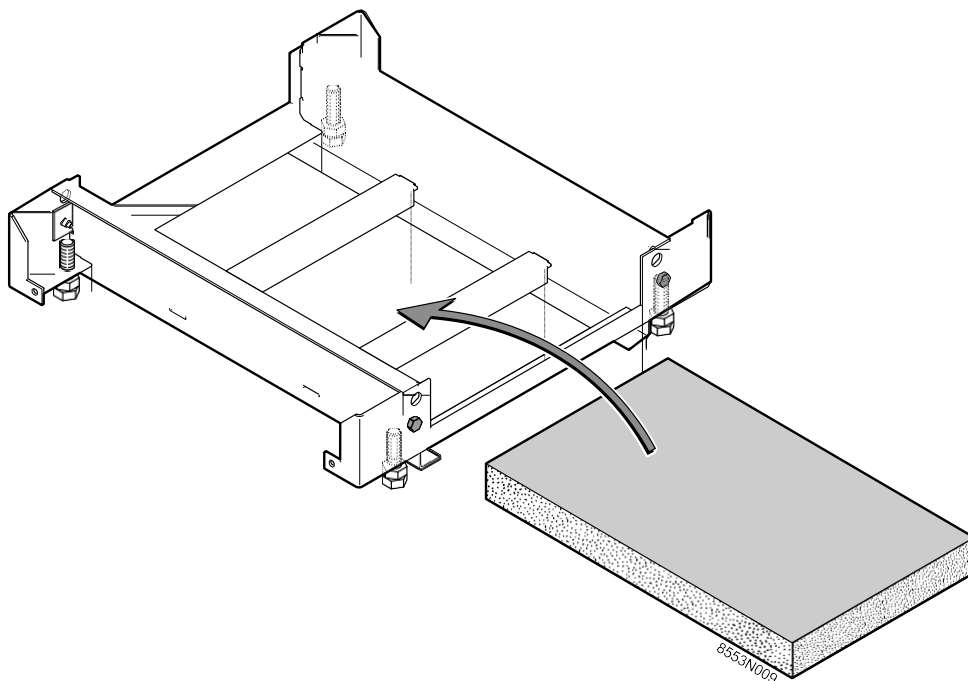
**2**

3

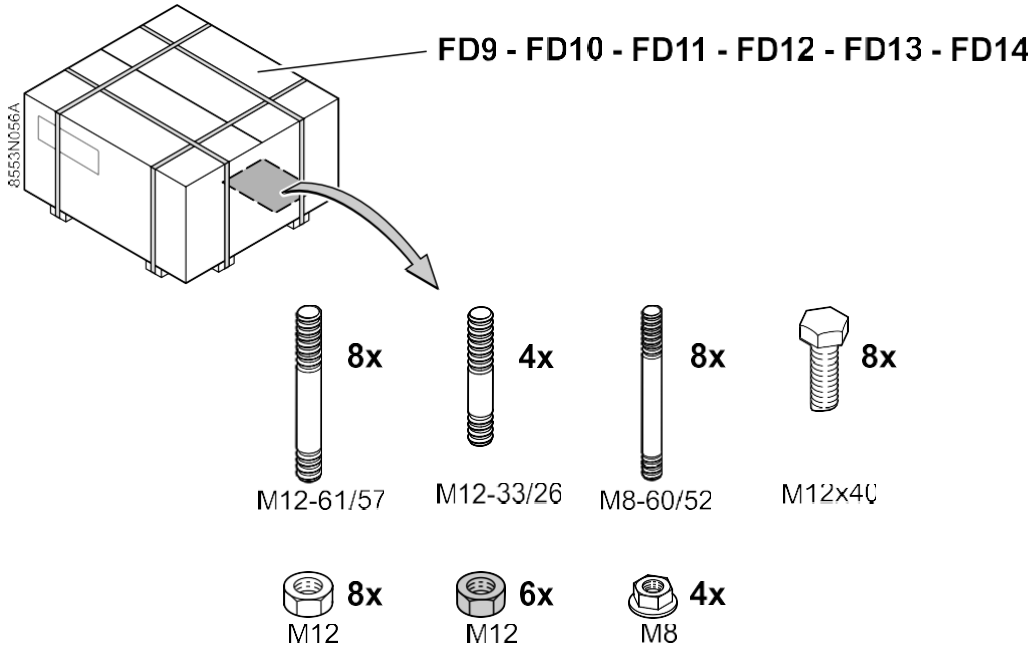

4

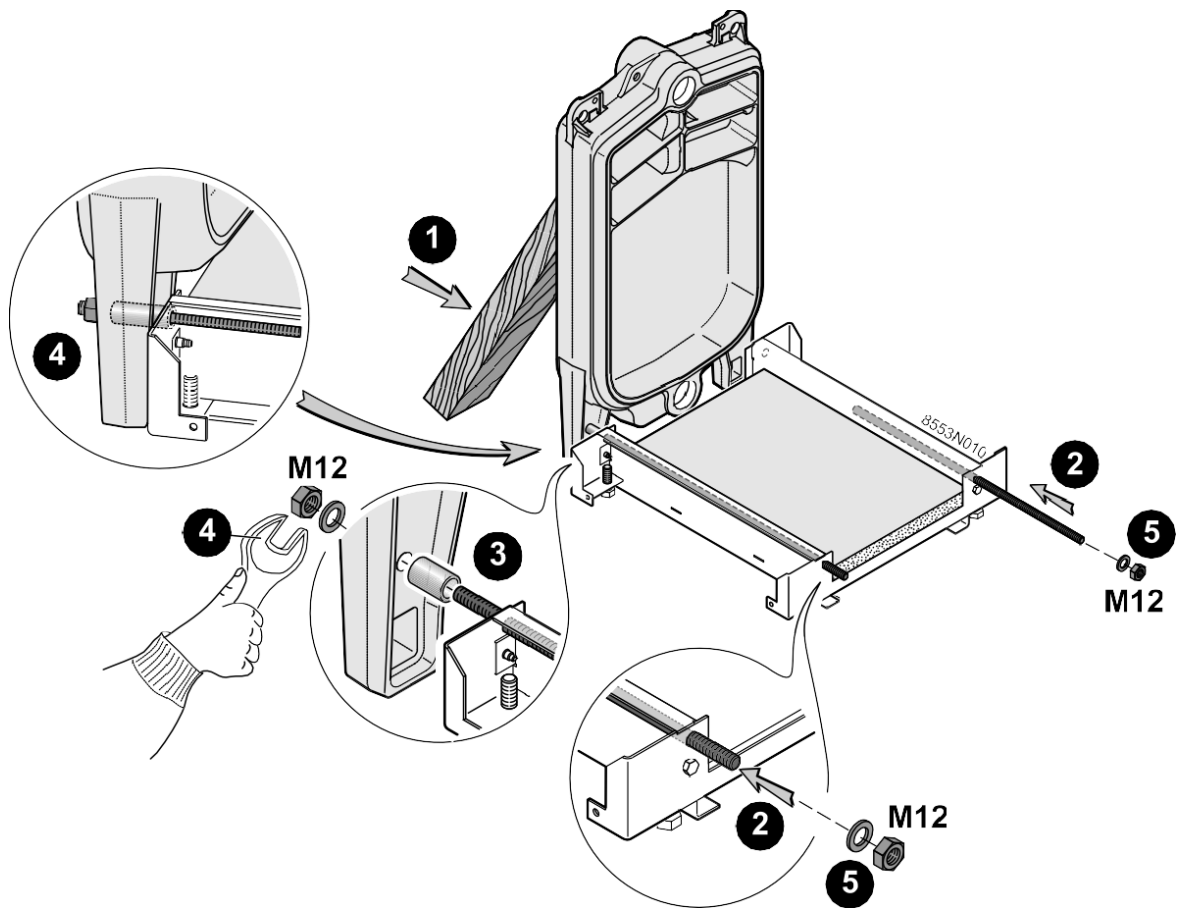

5

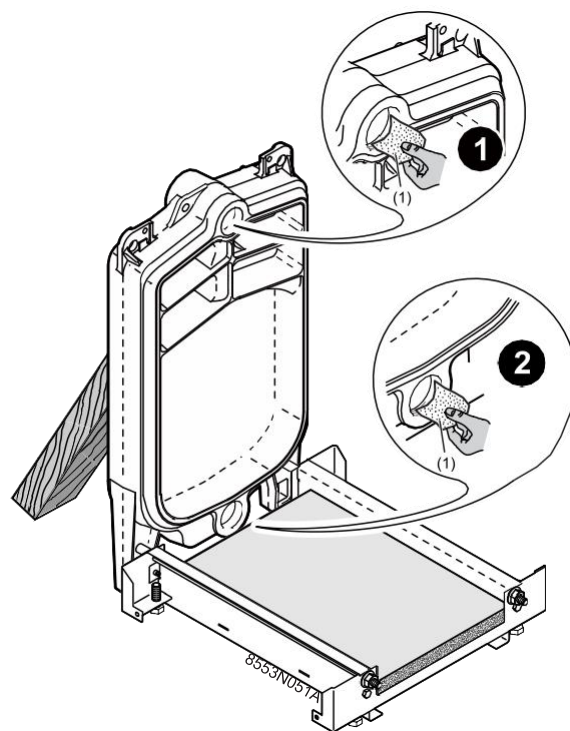

(1) Sandpaper

6

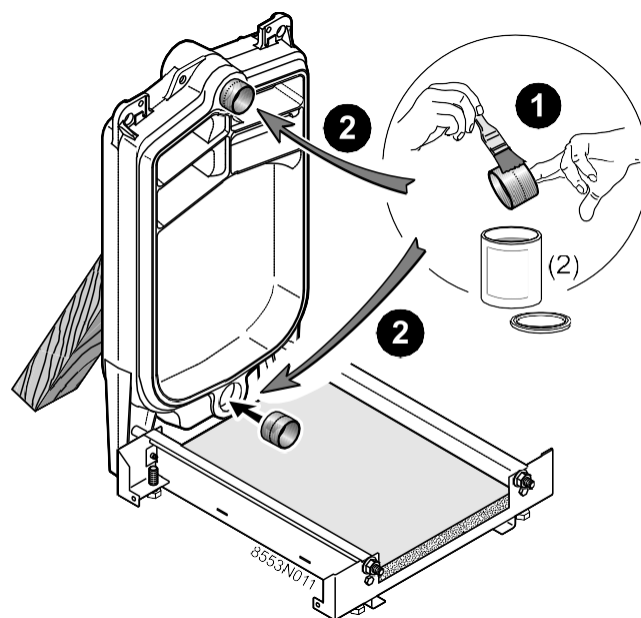

(2) Linseed oil (Supplied)

7

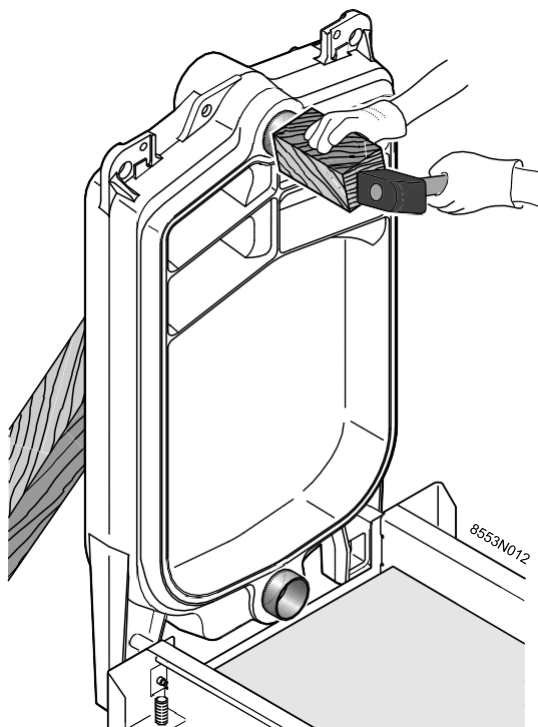

8

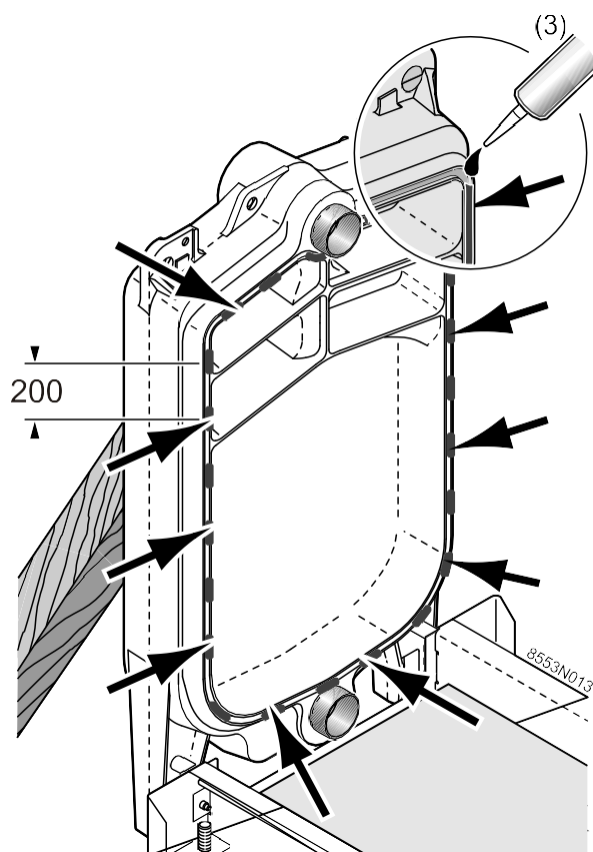

(3) Silicon (supplied)

9

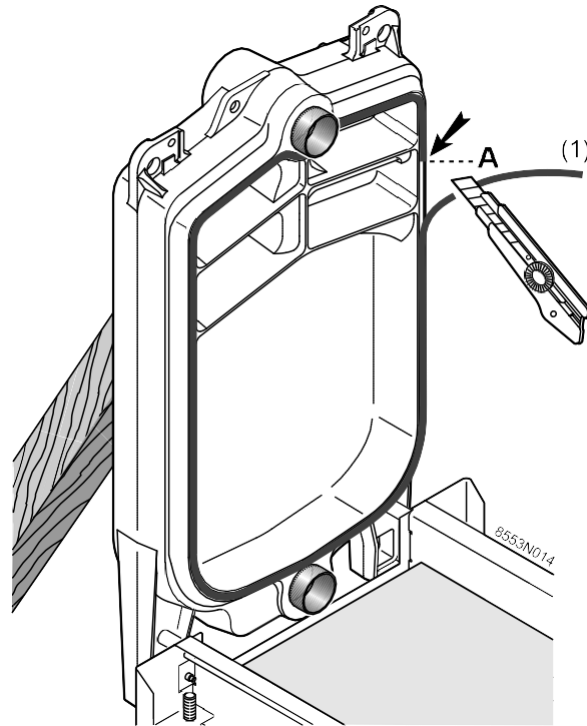

(1) Thermocord (Supplied)

10

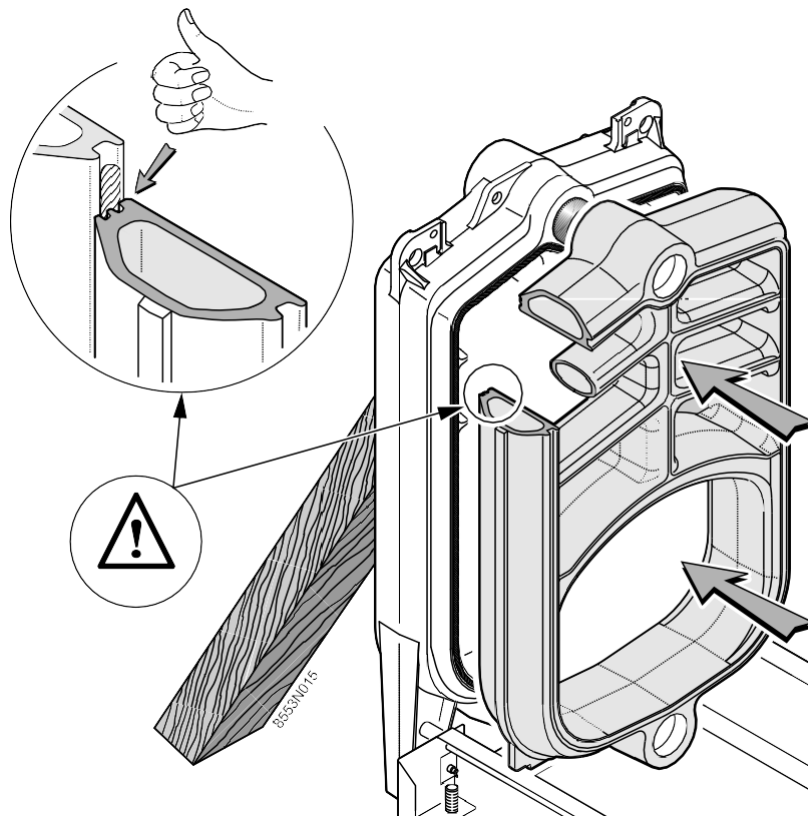

& Caution: Do not overtighten. Correct tightening is achieved when the cast iron sections come into contact.

11

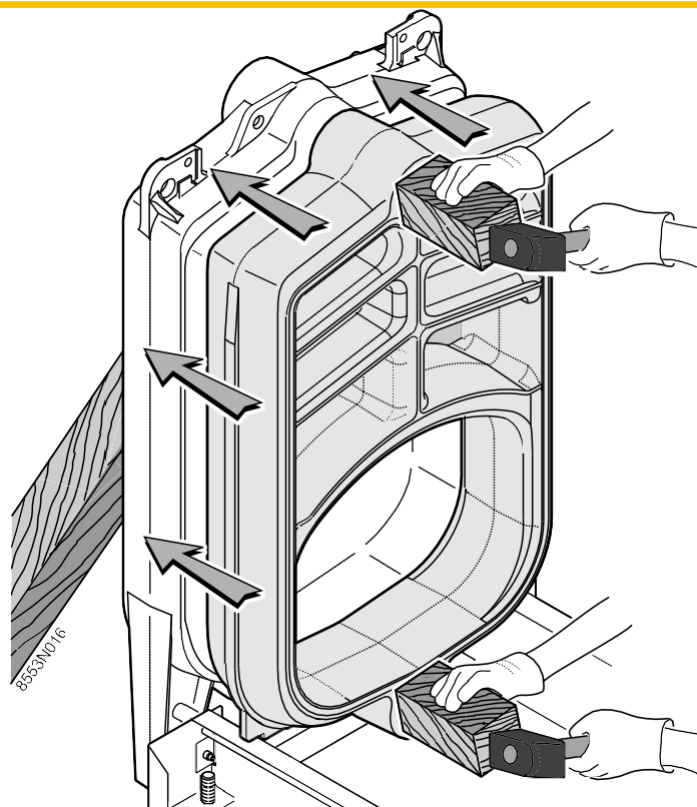

12

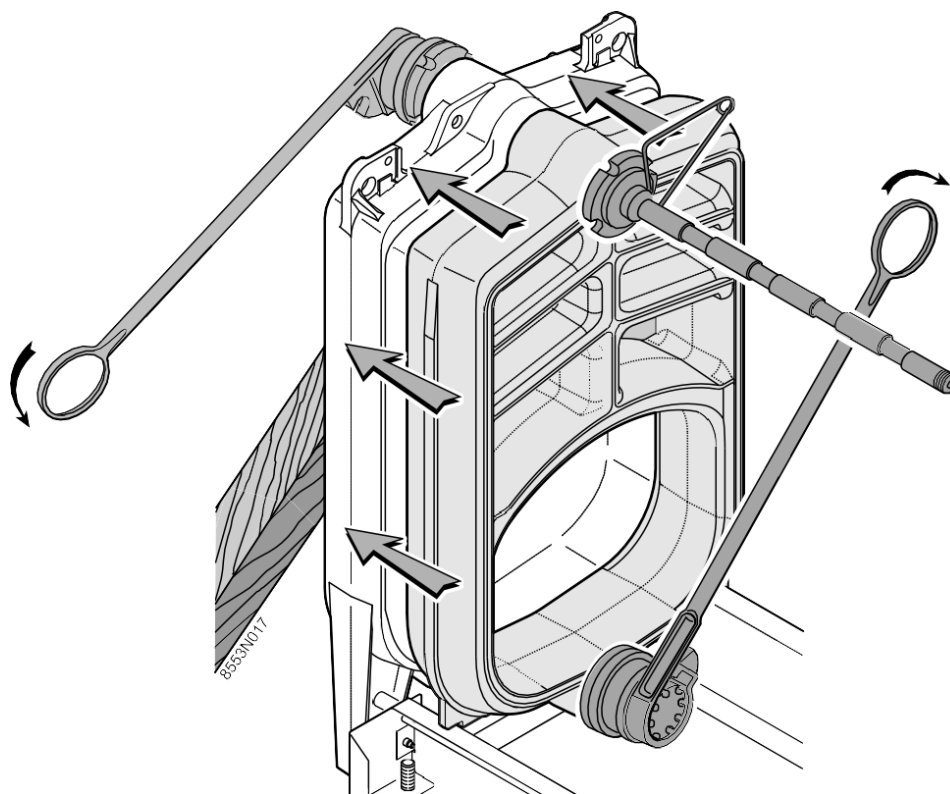

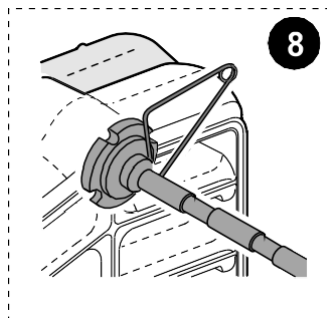
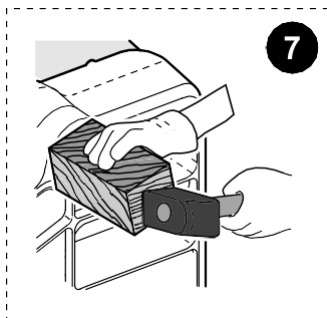
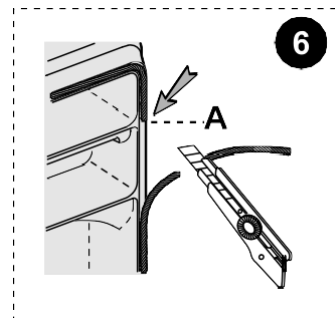
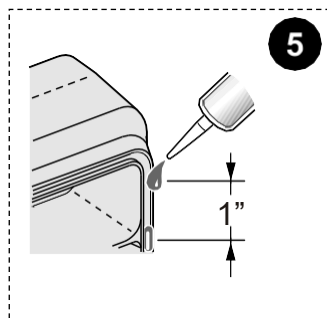
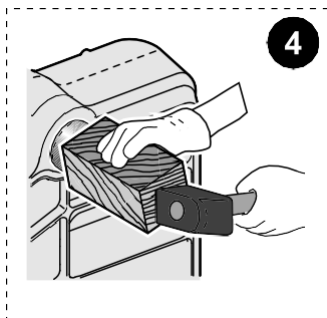
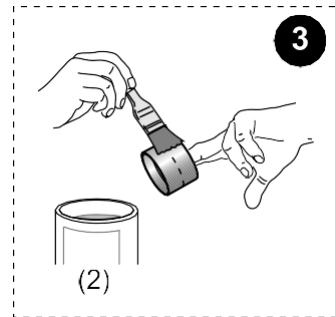
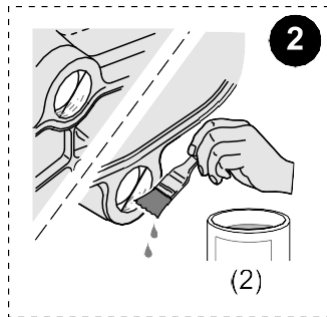
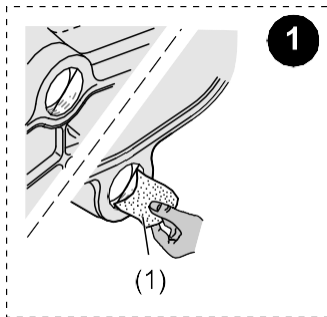
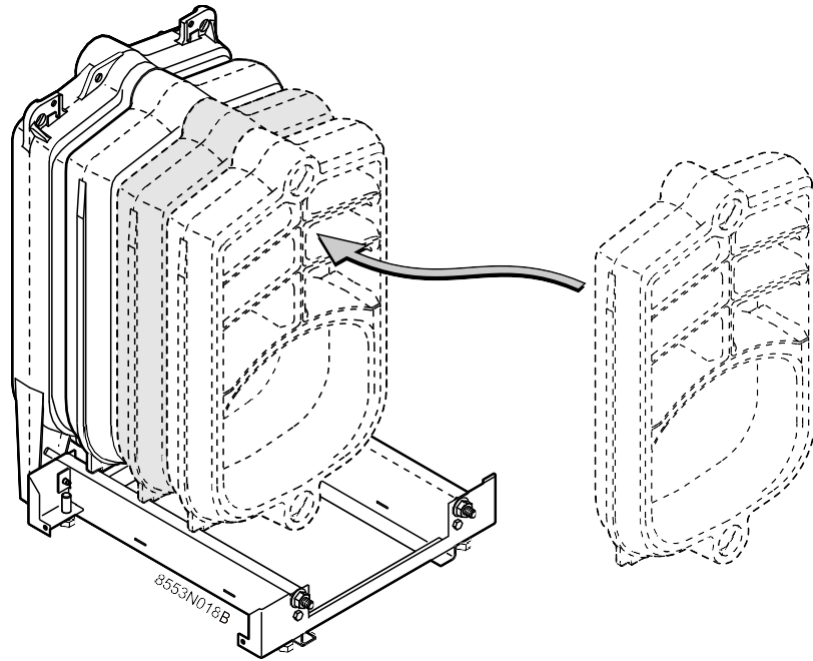

- (1) Sandpaper
- (2) Linseed oil (Supplied)

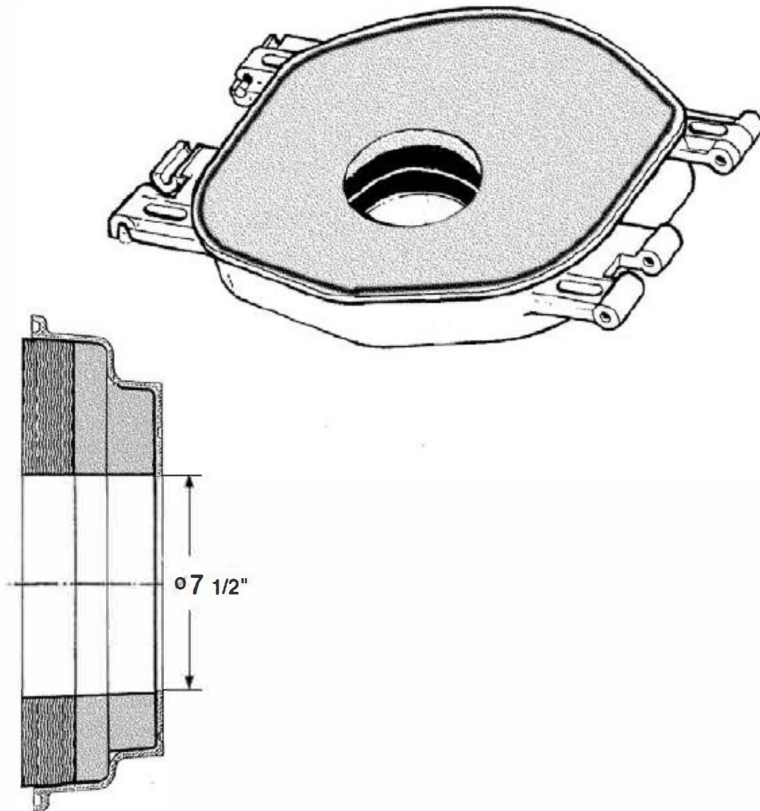
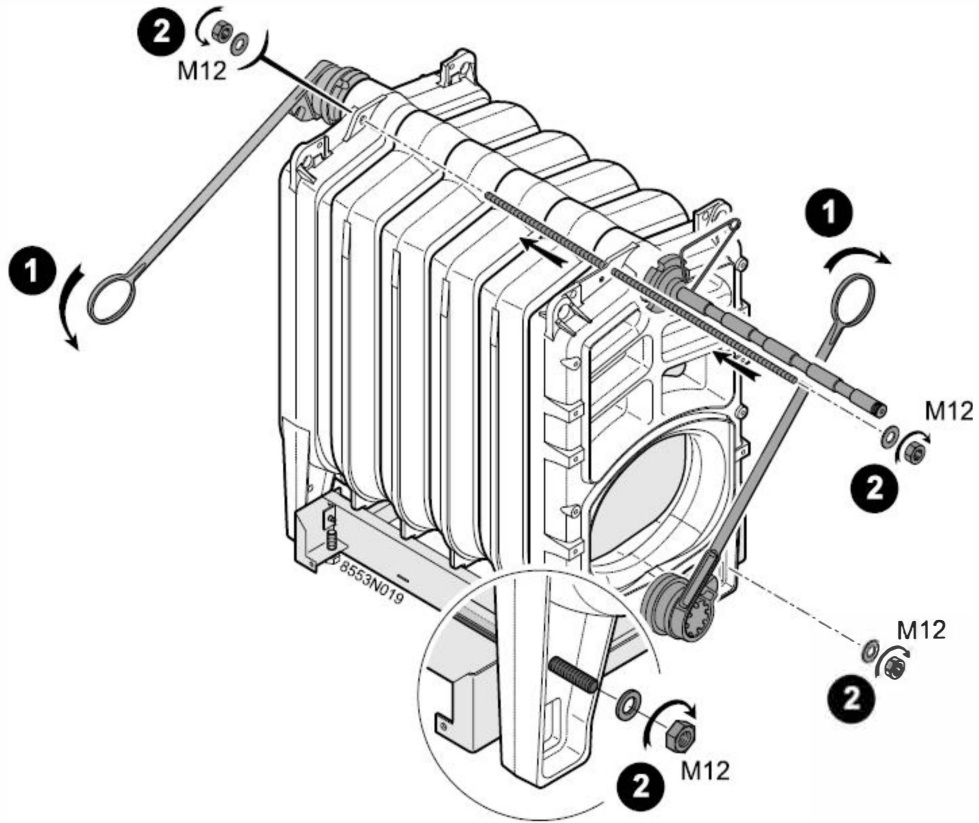

Adjust the thermal insulation to match the burner.

16

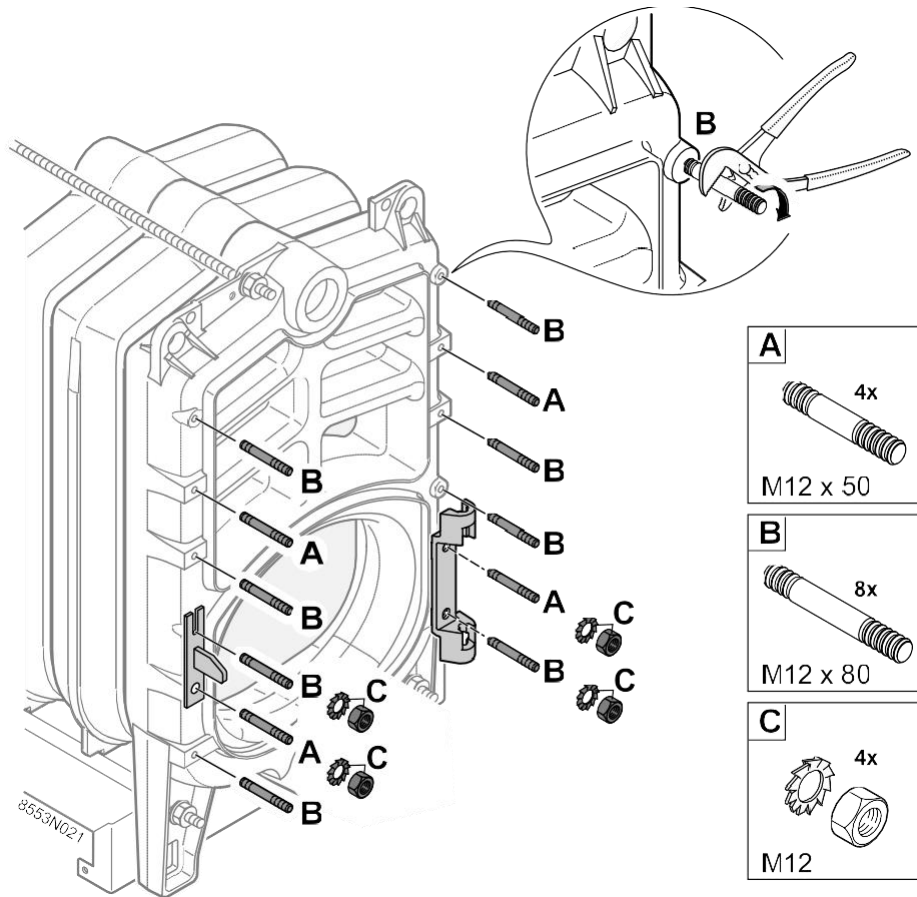

17

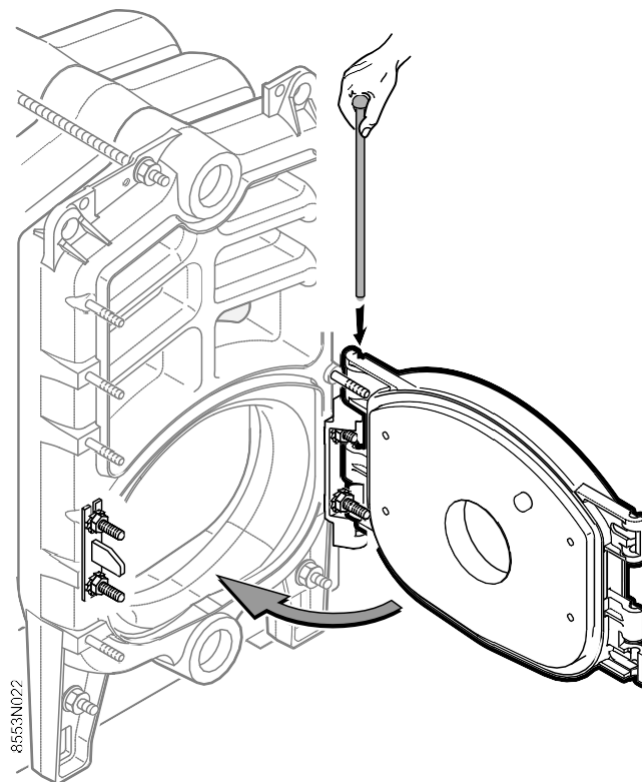

18

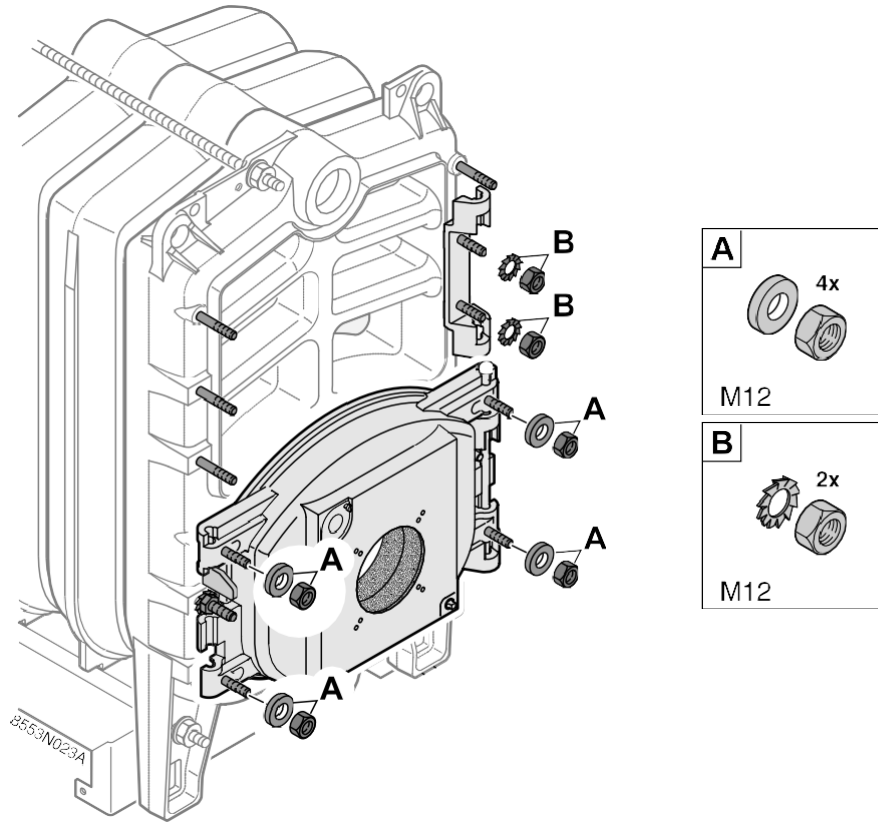

19

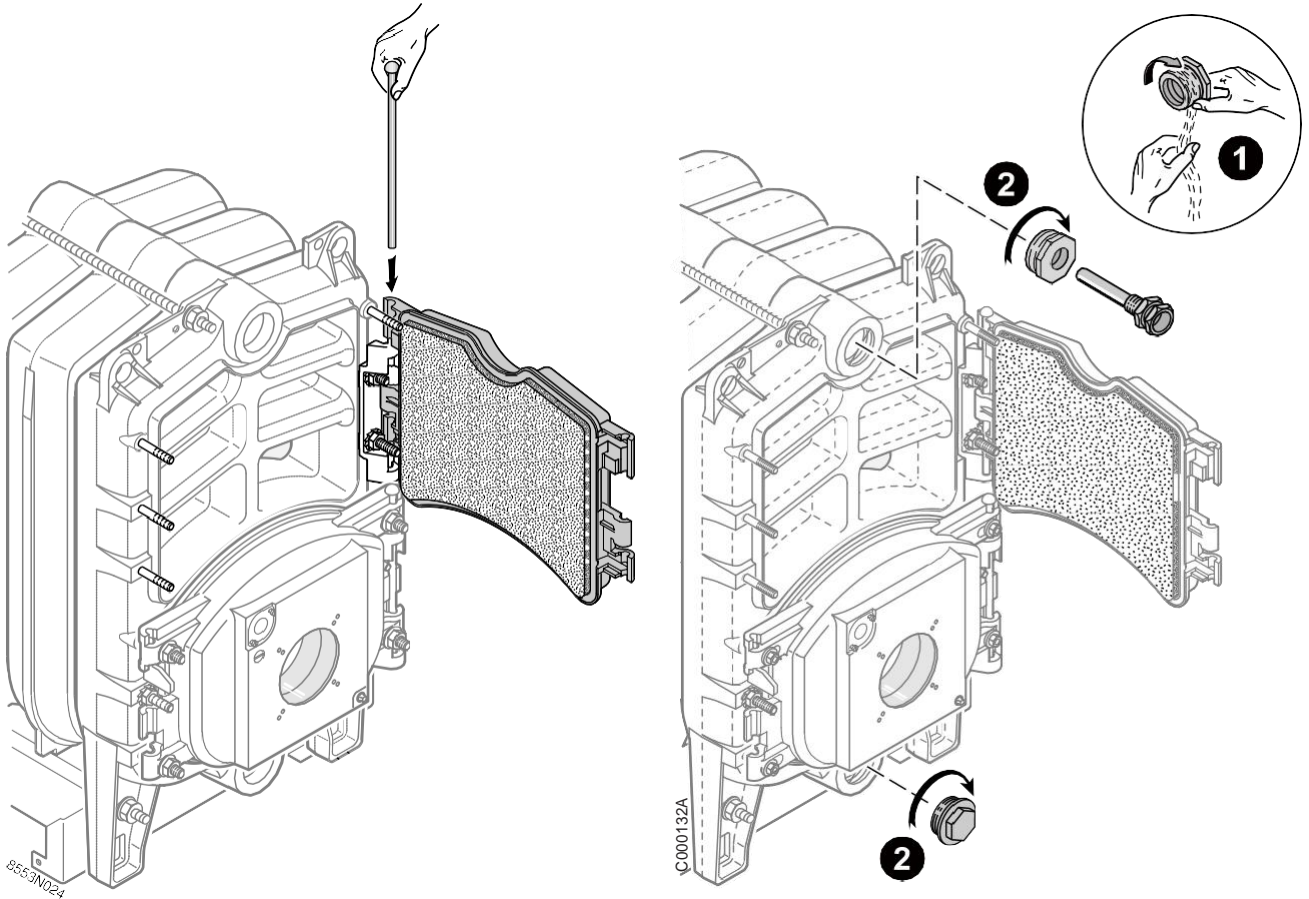

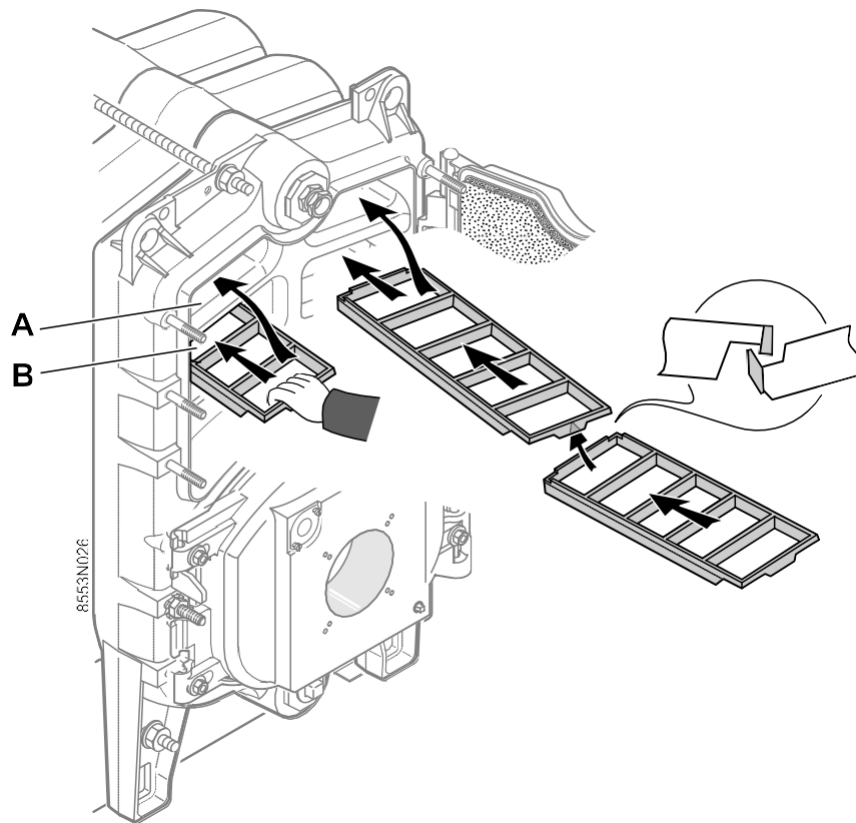

Baffle Position	Baffle	Fraction	mm	GT 334 A	GT 335 A	GT 336 A	GT 337 A	GT 338 A	GT 339 A
Upper [3rd Pass]	8219-0017	16 1/4	410	0	8	8	4	0	0
Middle [2nd Pass]	8219-0018	22 7/16	570	4	0	0	4	8	8
Lower [1st Pass]	8219-0019	16 1/4	412	2	2	2	2	4	2
	8219-0020	22 1/2	572	0	0	0	0	0	2

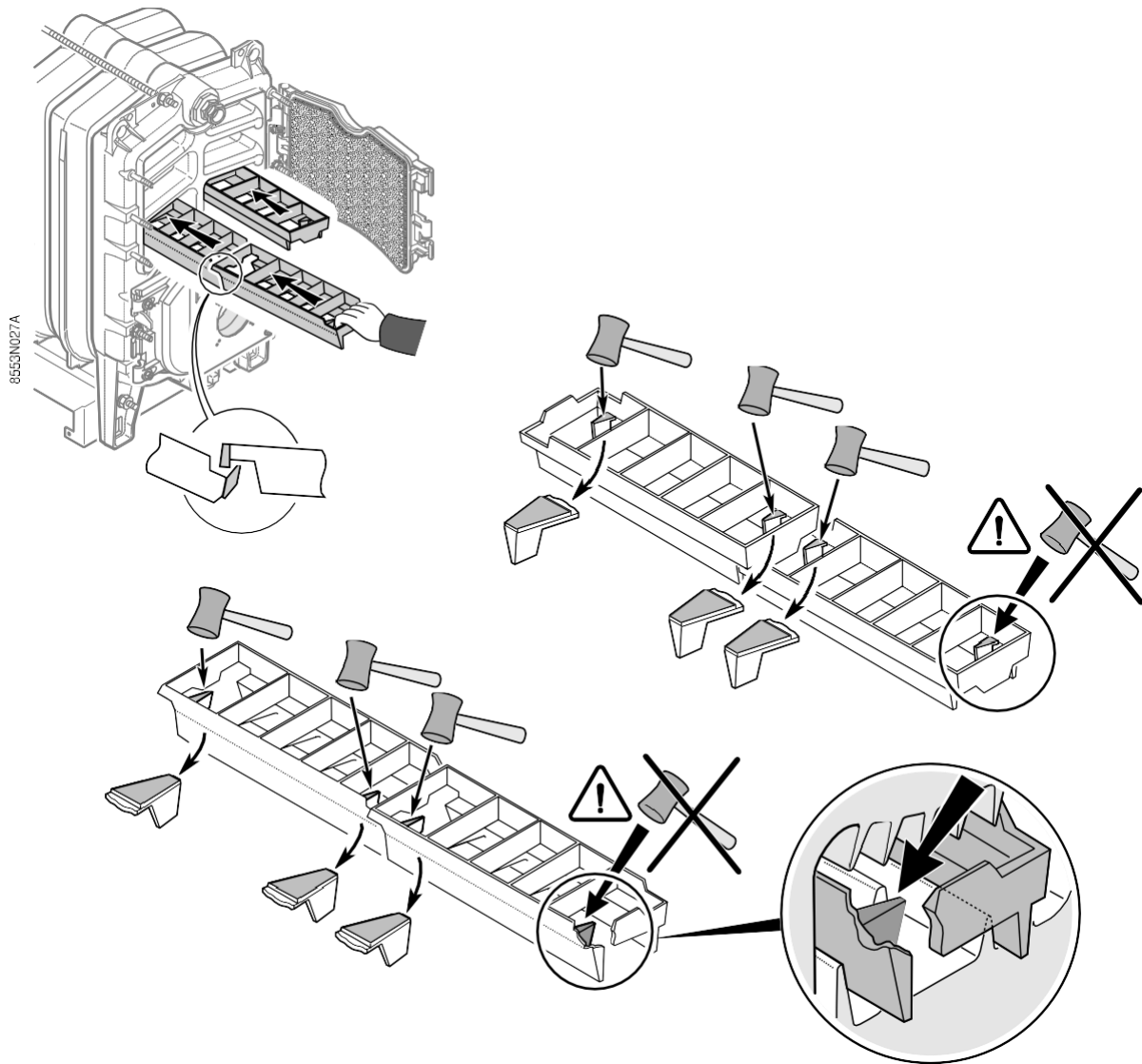

Baffle Position	Baffle	Fraction	mm	GT 334 A	GT 335 A	GT 336 A	GT 337 A	GT 338 A	GT 339 A
Upper [3rd Pass]	8219-0017	16 1/4	410	0	8	8	4	0	0
Middle [2nd Pass]	8219-0018	22 7/16	570	4	0	0	4	8	8
Lower [1st Pass]	8219-0019	16 1/4	412	2	2	2	2	4	2
	8219-0020	22 1/2	572	0	0	0	0	0	2

22

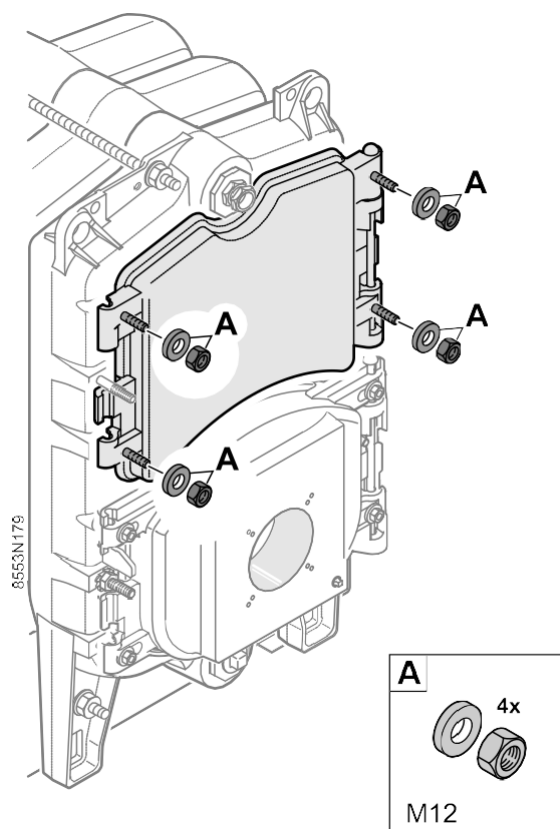

23

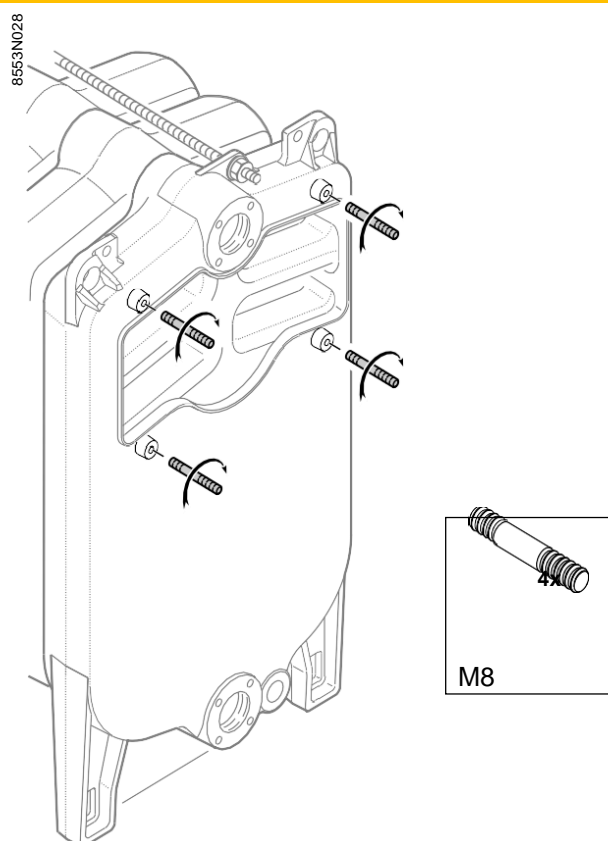

24

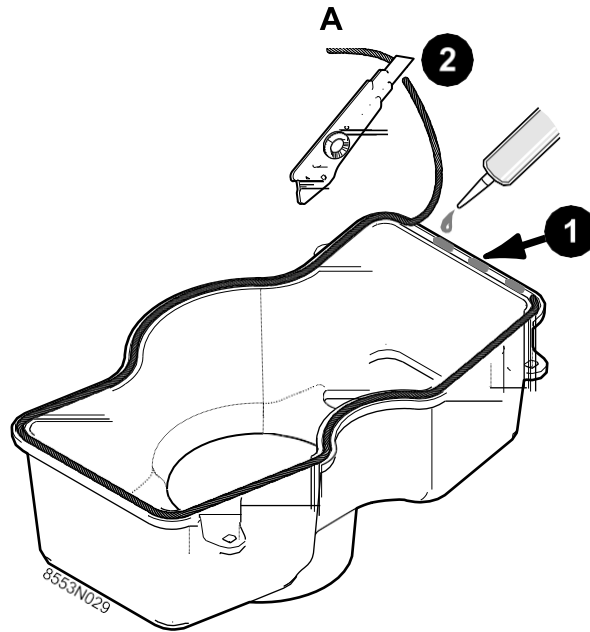

(A) Thermocord

25

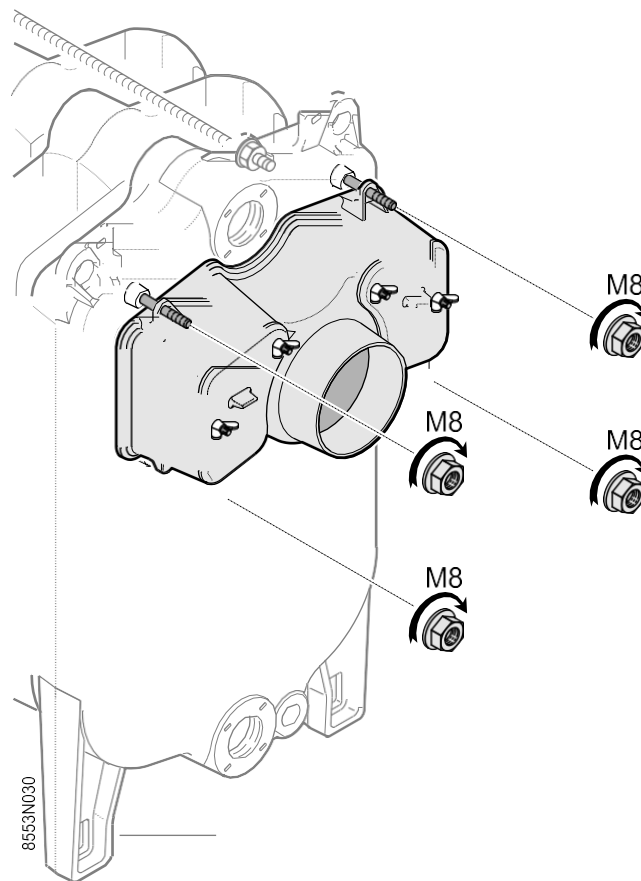

26

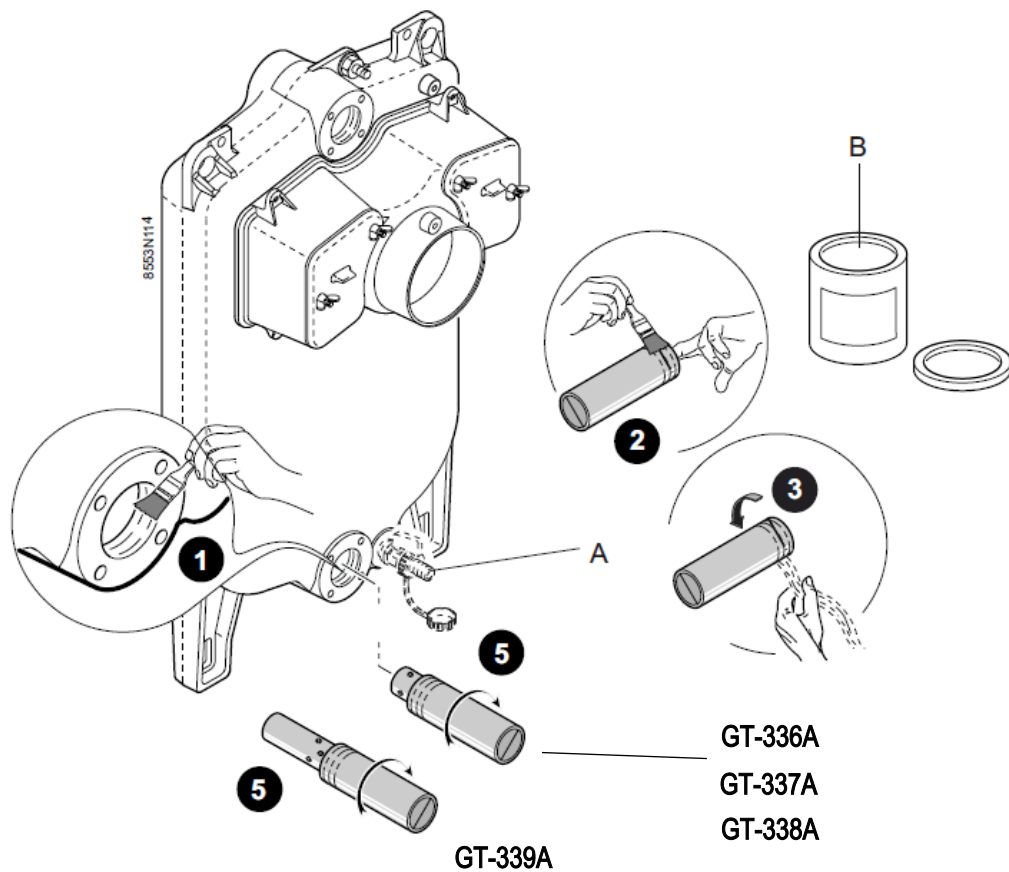

A. Drain tap (not supplied)

B. Tightness sealant (not supplied)

27

28 Hydraulic test

After assembling the boiler body, the installer must carry out a water tightness test at a pressure equal to 1.5 times the operating pressure (that is 90* PSI minimum) for 30 minutes at least. The test must be done at room temperature.

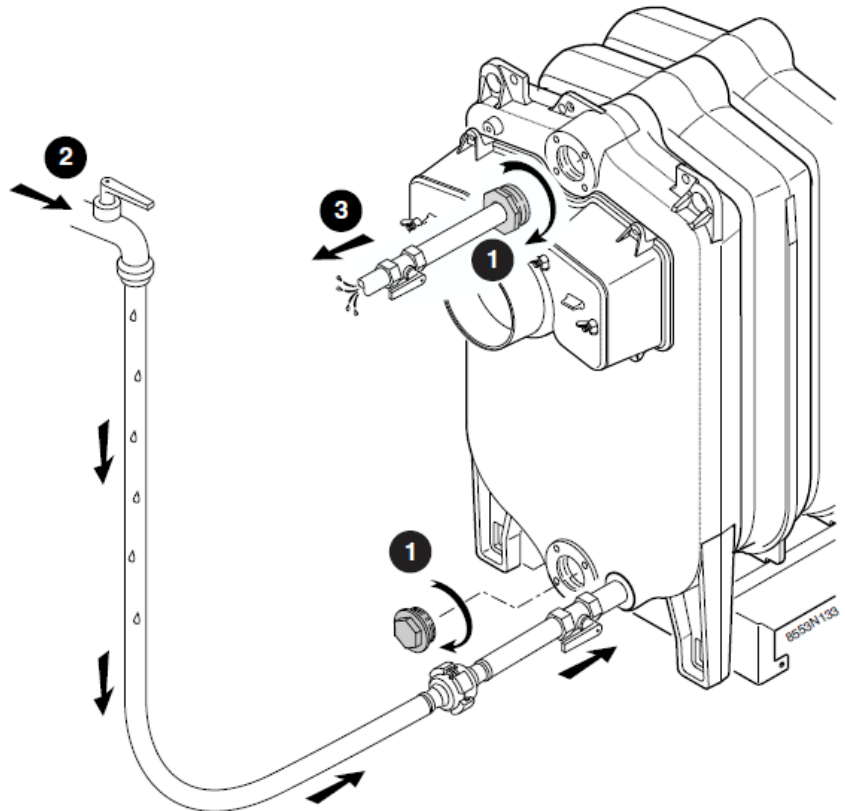

& Ensure that all the air in the boiler is vented to avoid any bursting of the body.

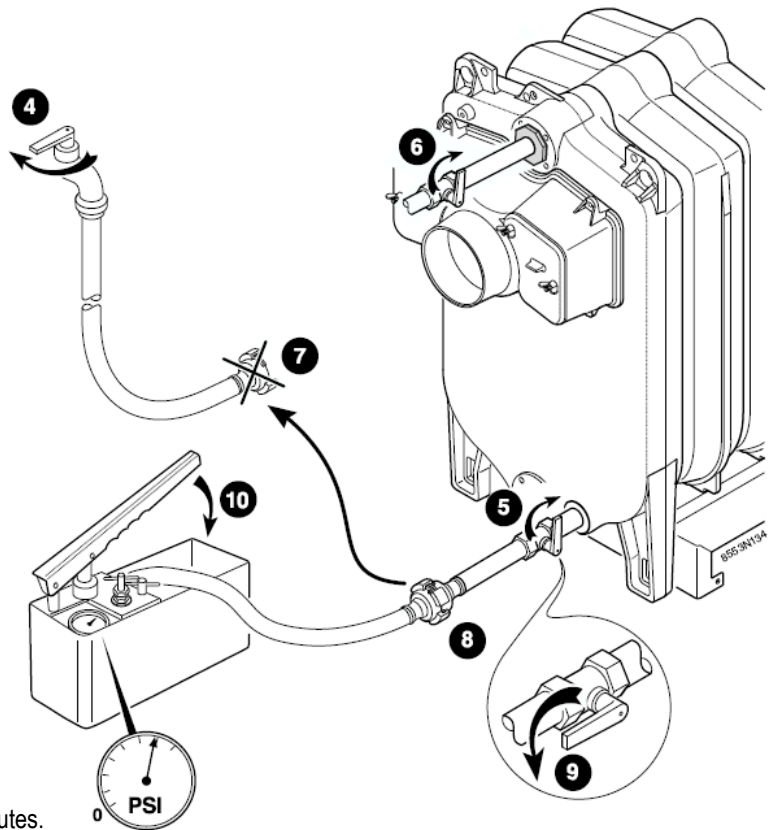

90* PSI: Maintain pressure for at least 30 minutes.

i Any drop in pressure indicates a leakage in the boiler body.

29

MD7- MD8 - MD9 - MD10 - MD11 - MD12

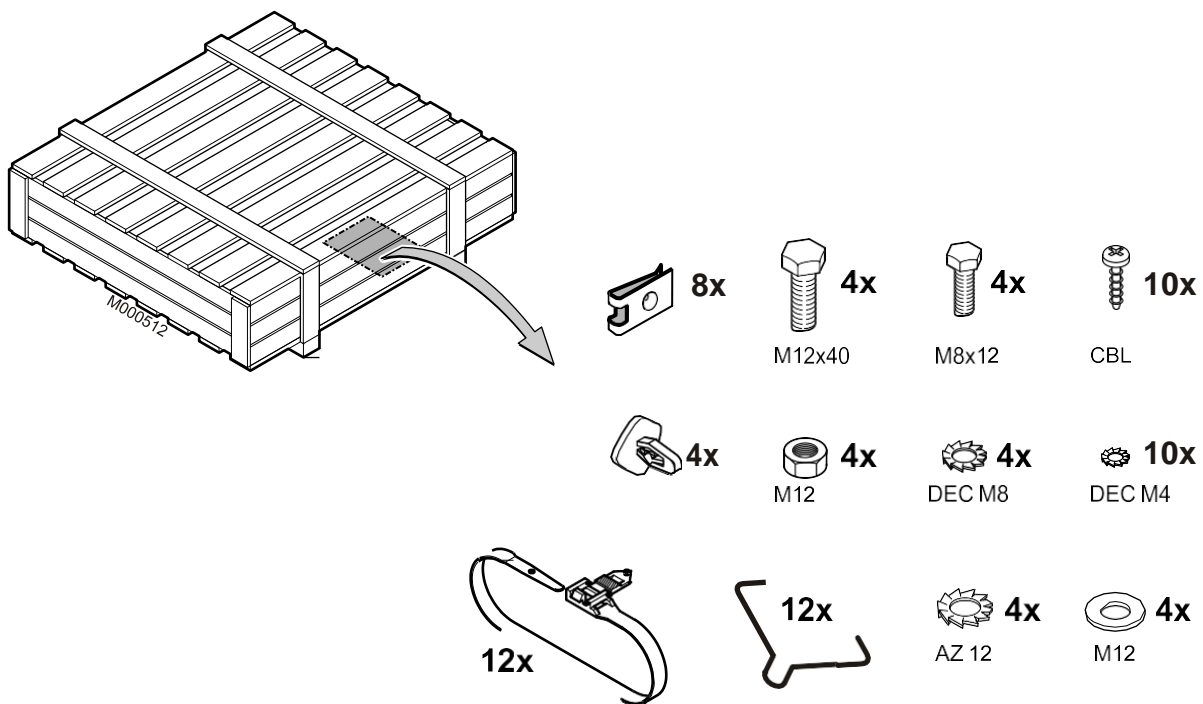

30

4-5-6-7 section boilers

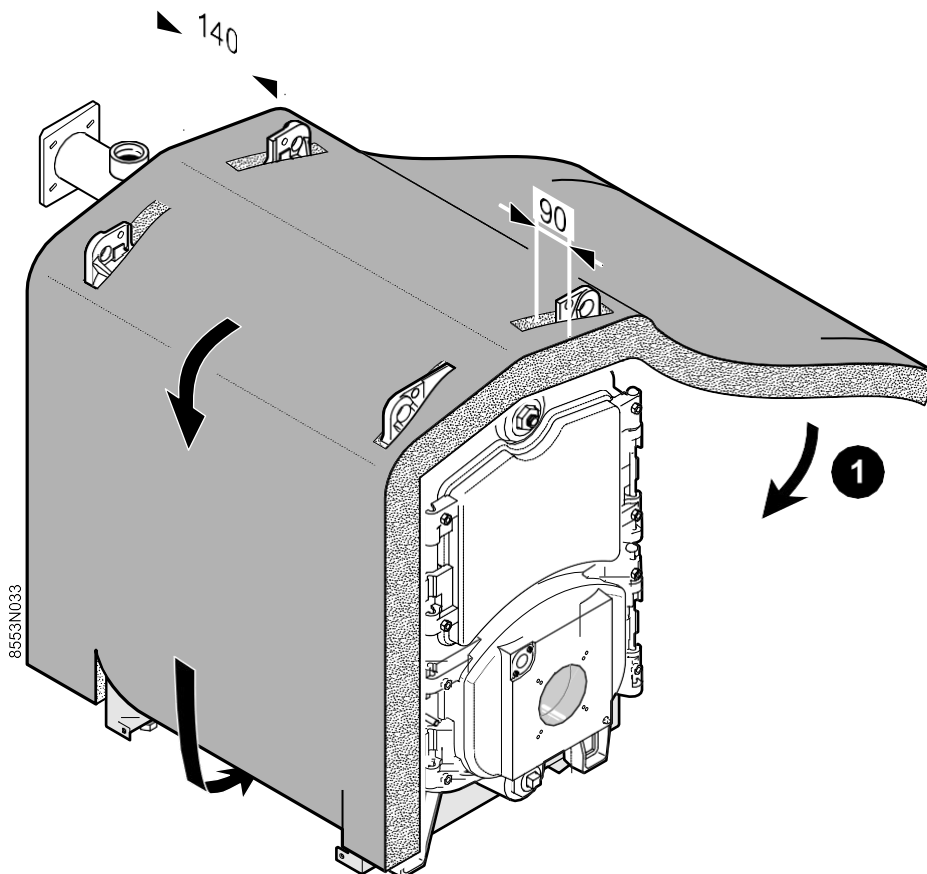

31

8-9 section boilers

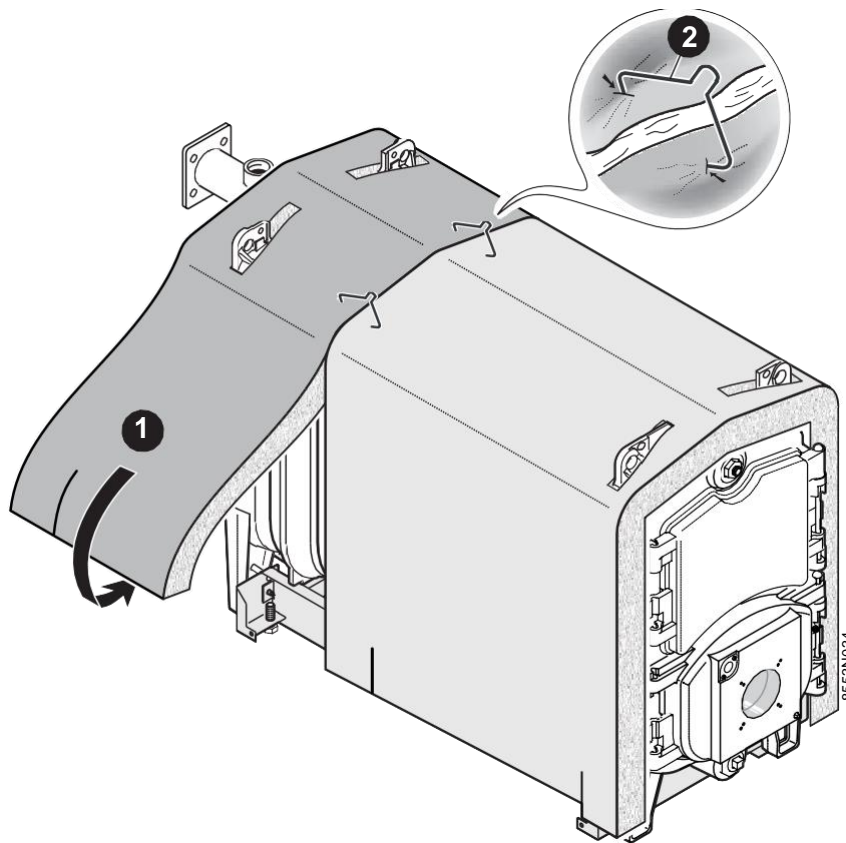

32

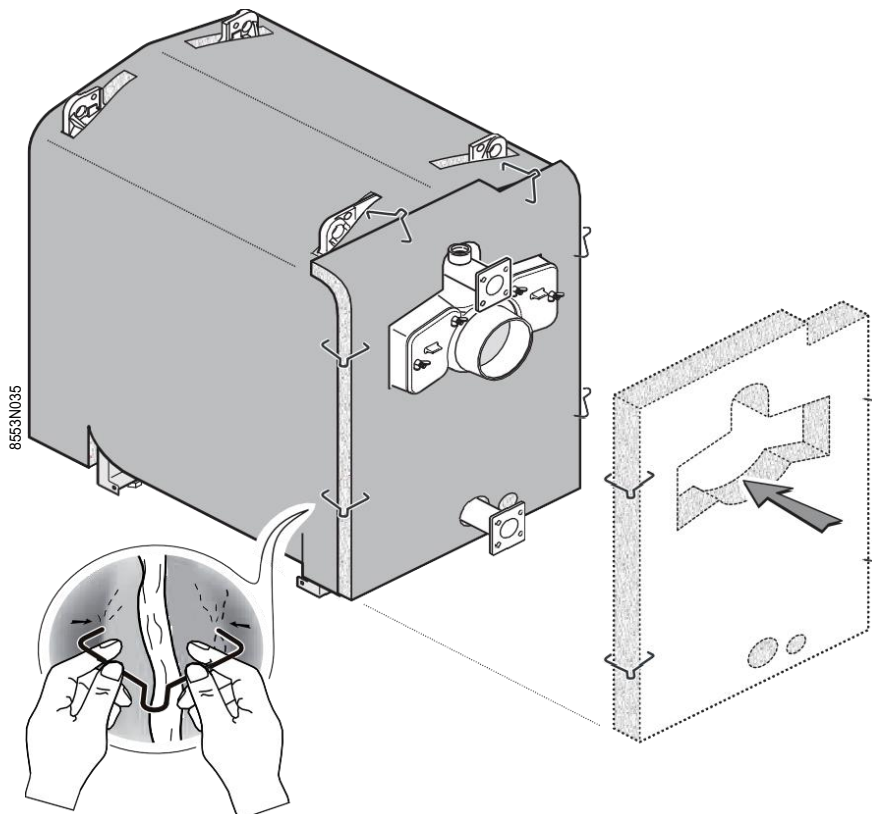

33

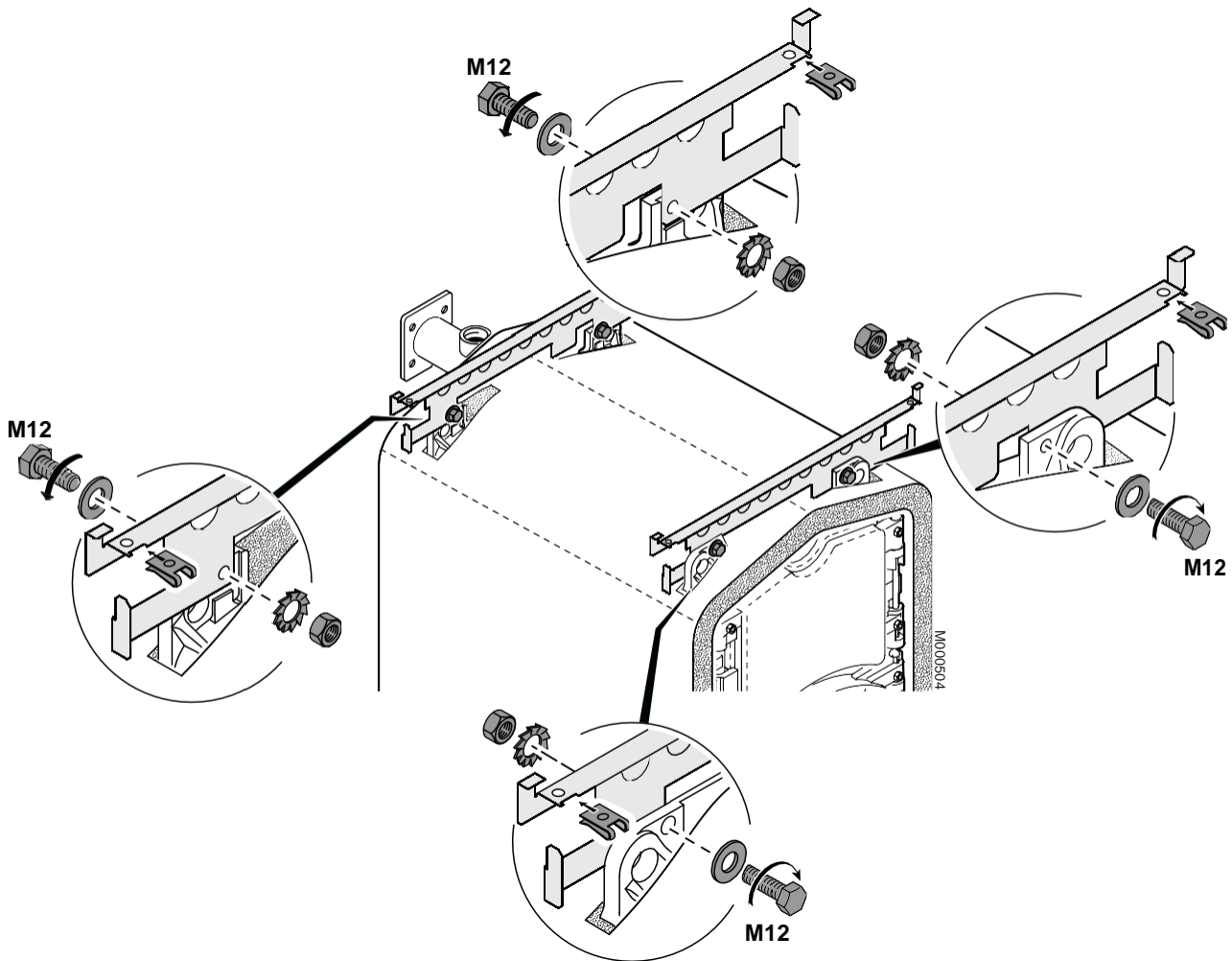

34

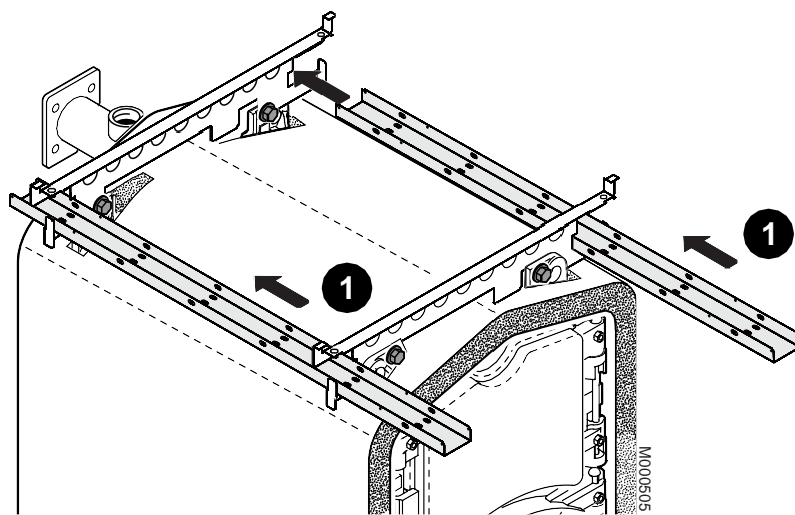

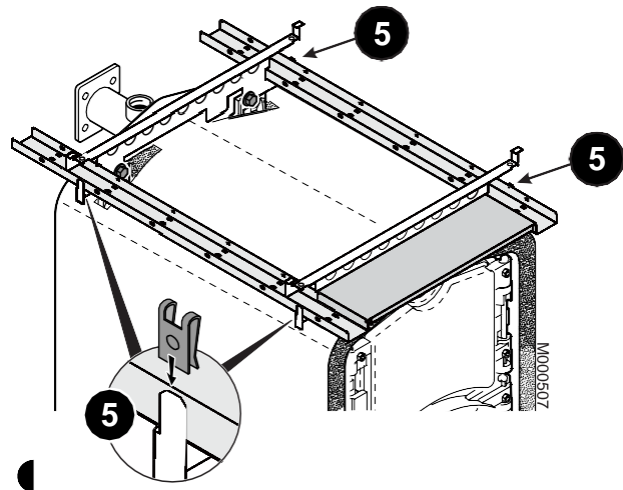
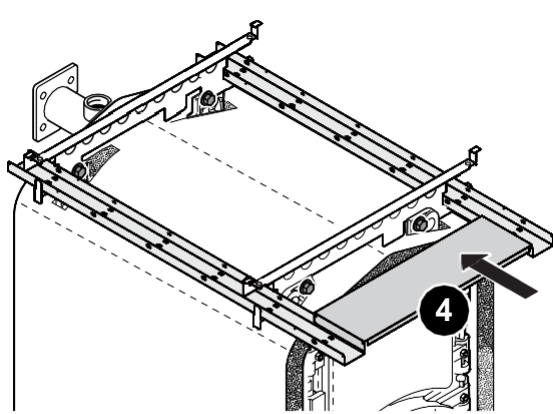
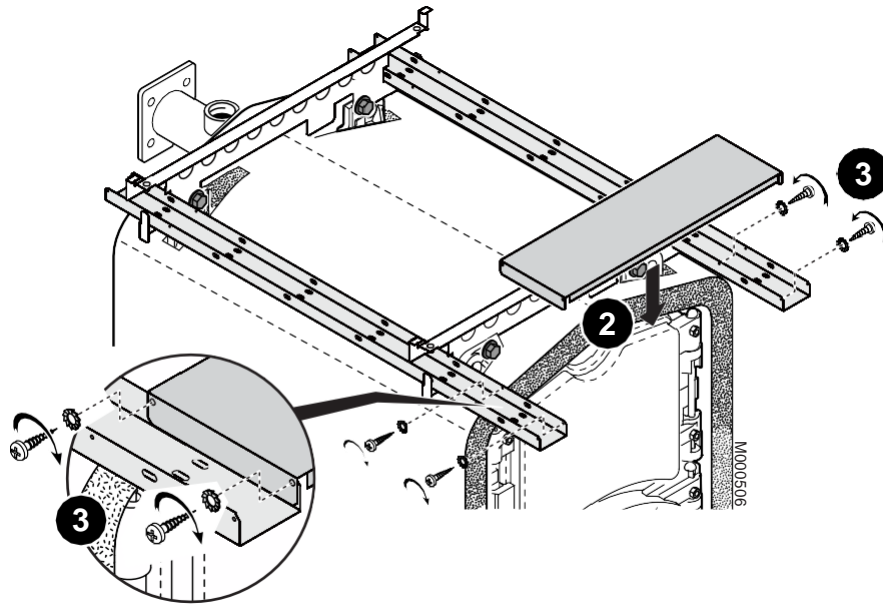

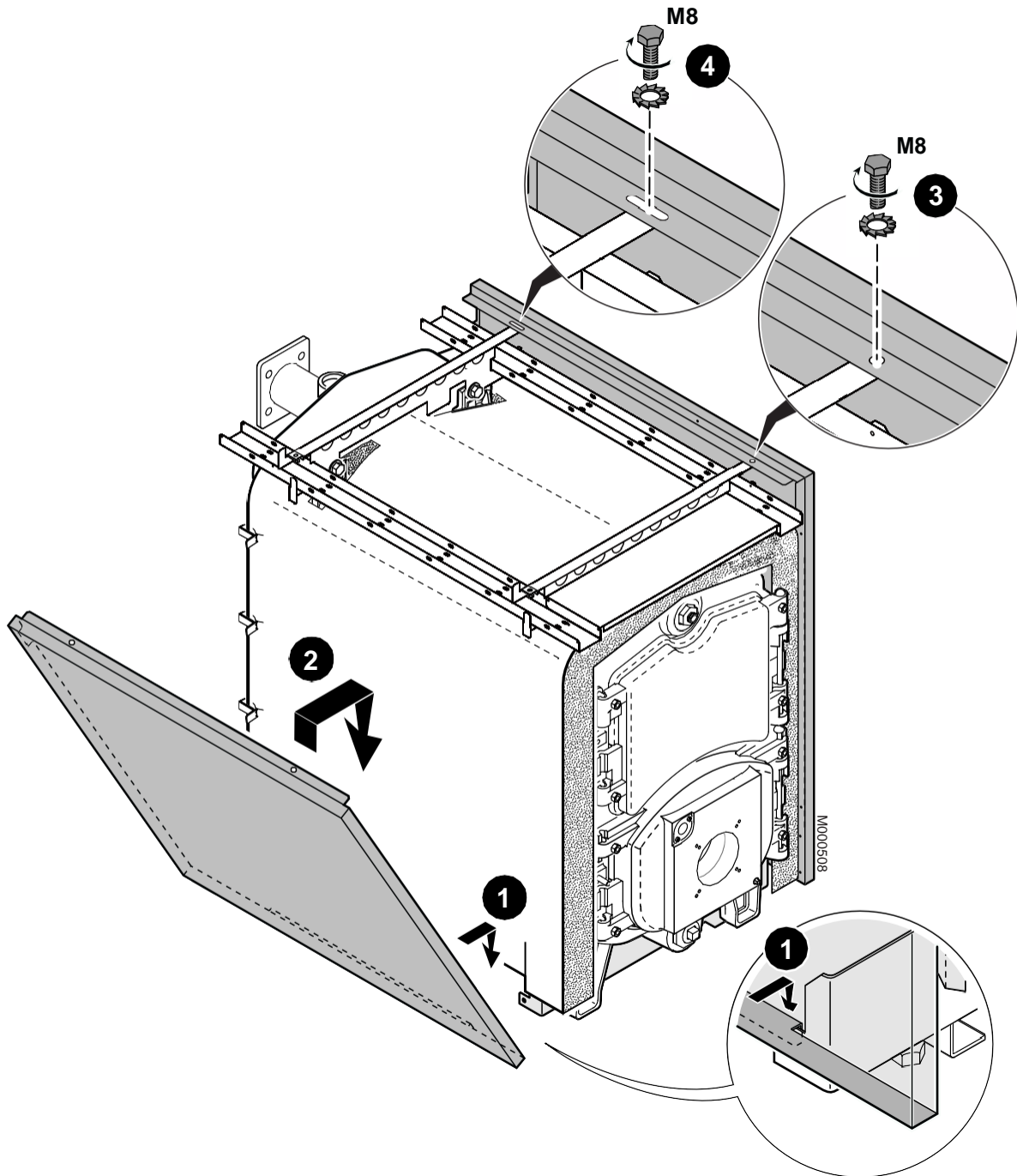

36

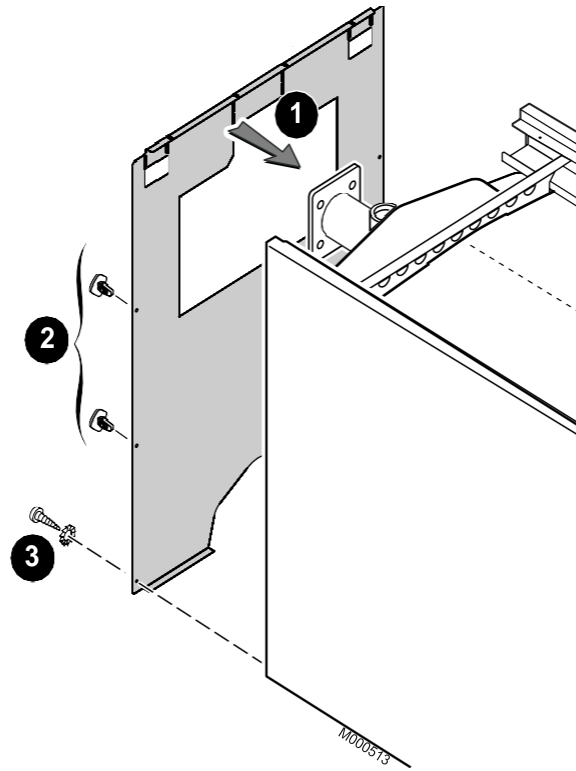

37

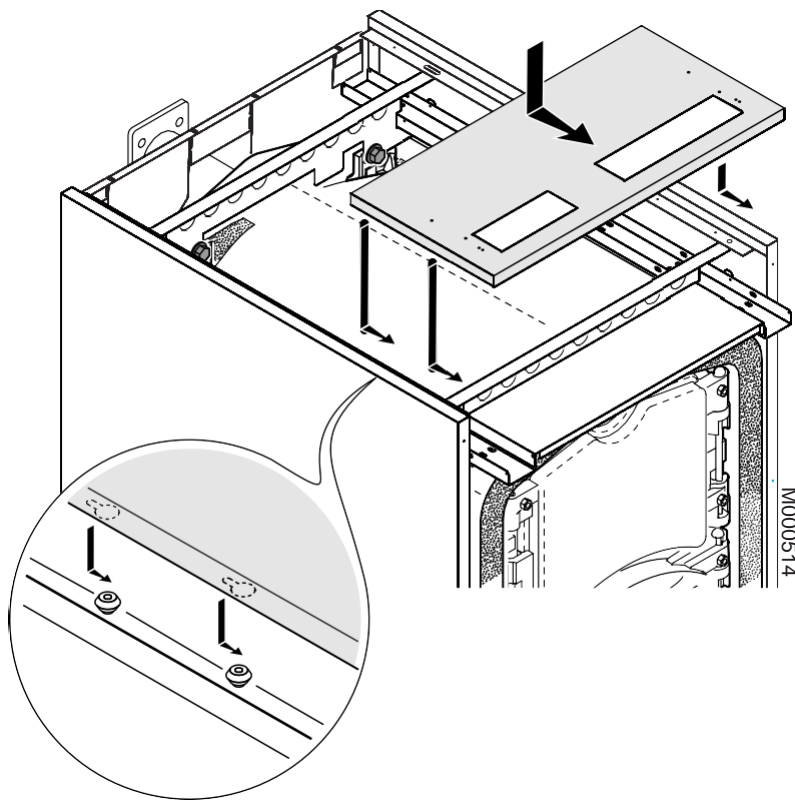

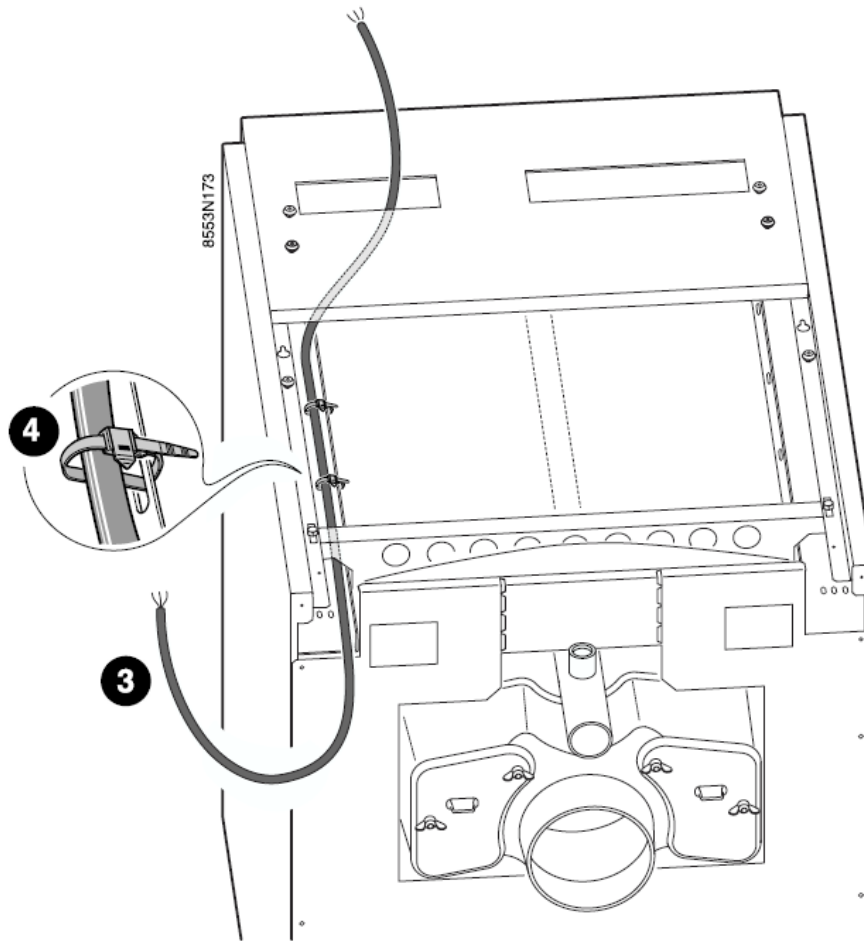

③ 120 V - 60 Hz

39 Control Panel Assembly

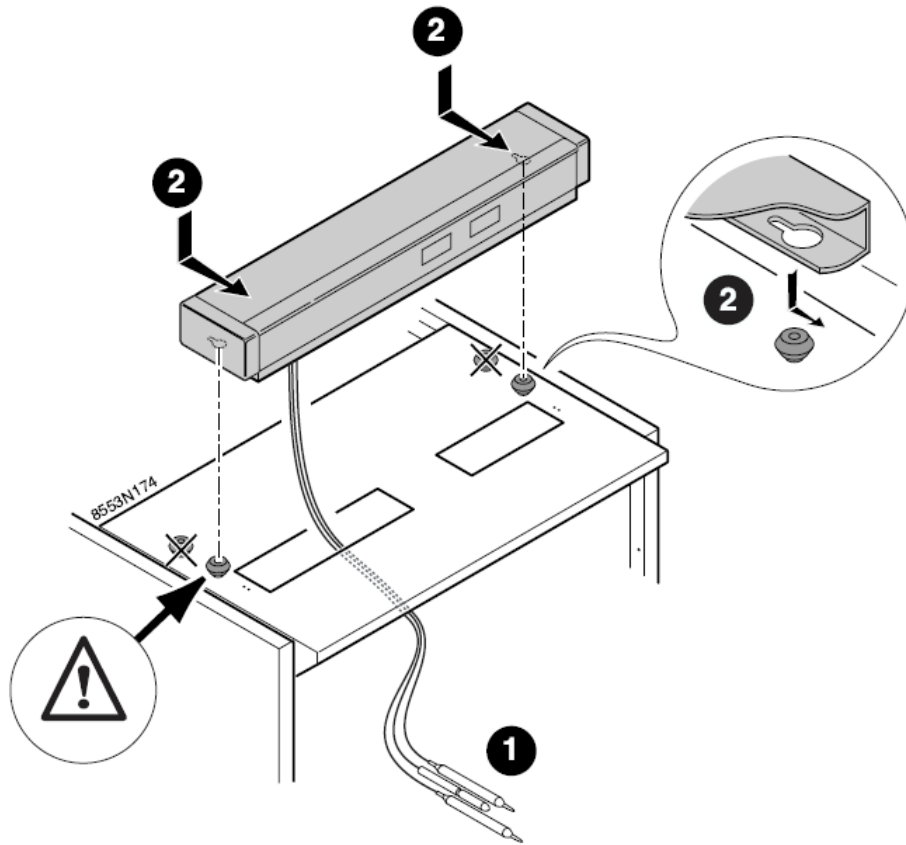

40 Control Panel Assembly

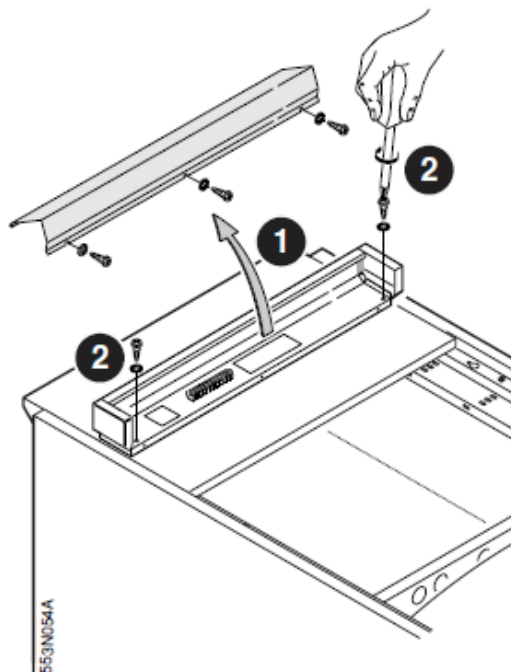

41

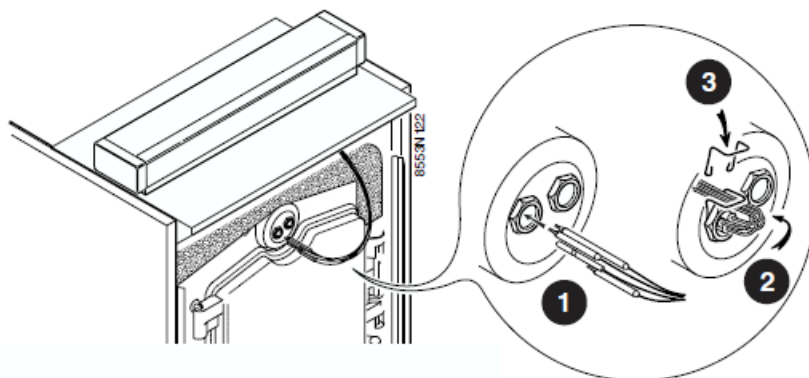

Carefully unwind the sensor bulbs and pass them through the opening in the front top cover. Insert them into the one well and secure them with the spring. The extra well is for auxiliary high temperature limit with manual reset.

42

Make the electrical connections to the terminal strip provided inside the control panel. Close the control panel (2 self-tapping screws + lockwashers).

43

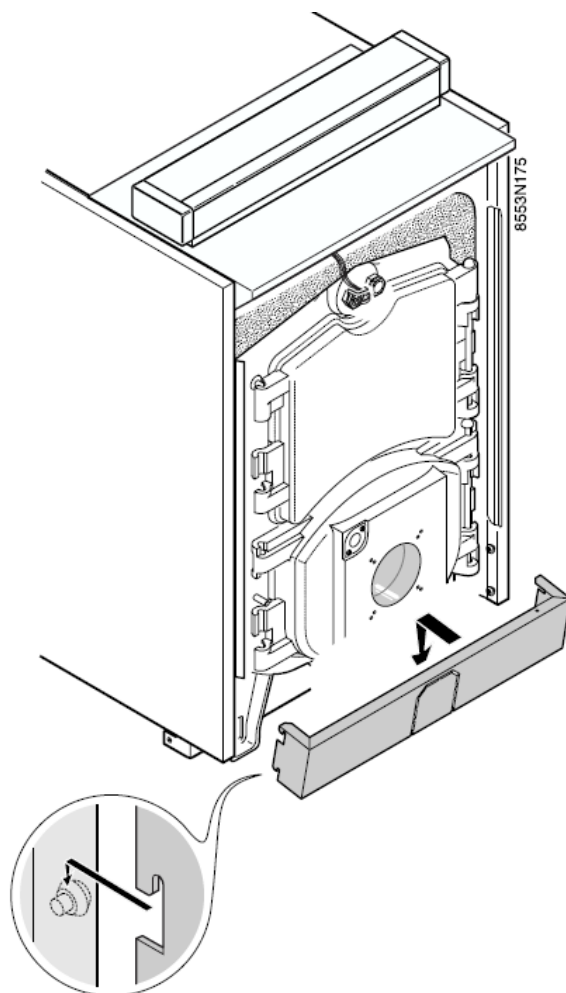

44

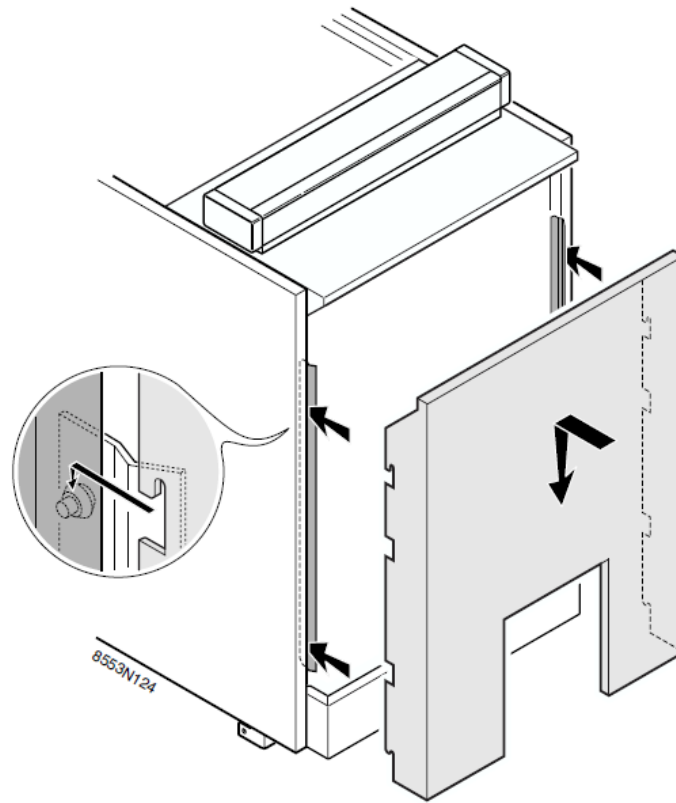

45

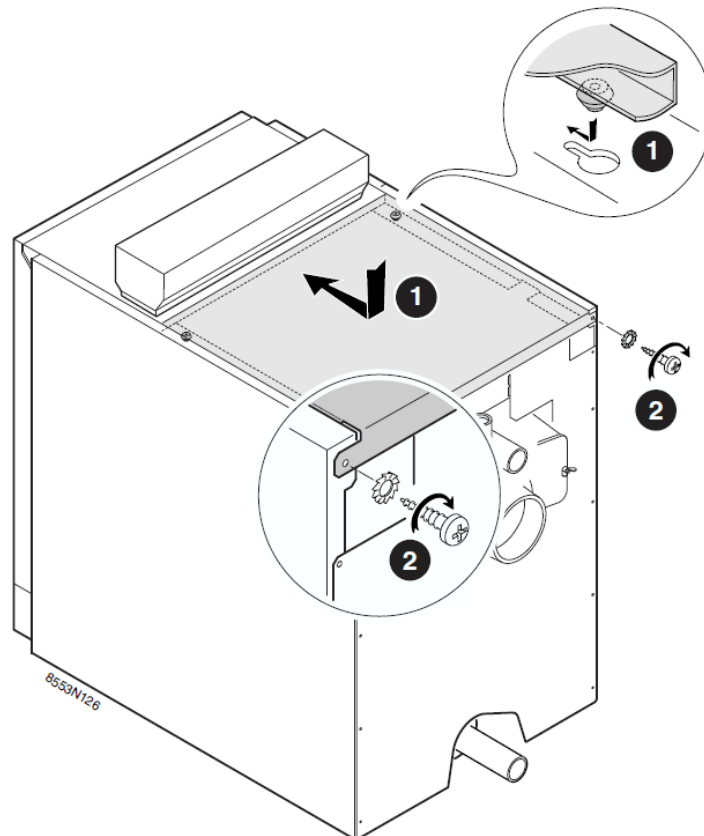

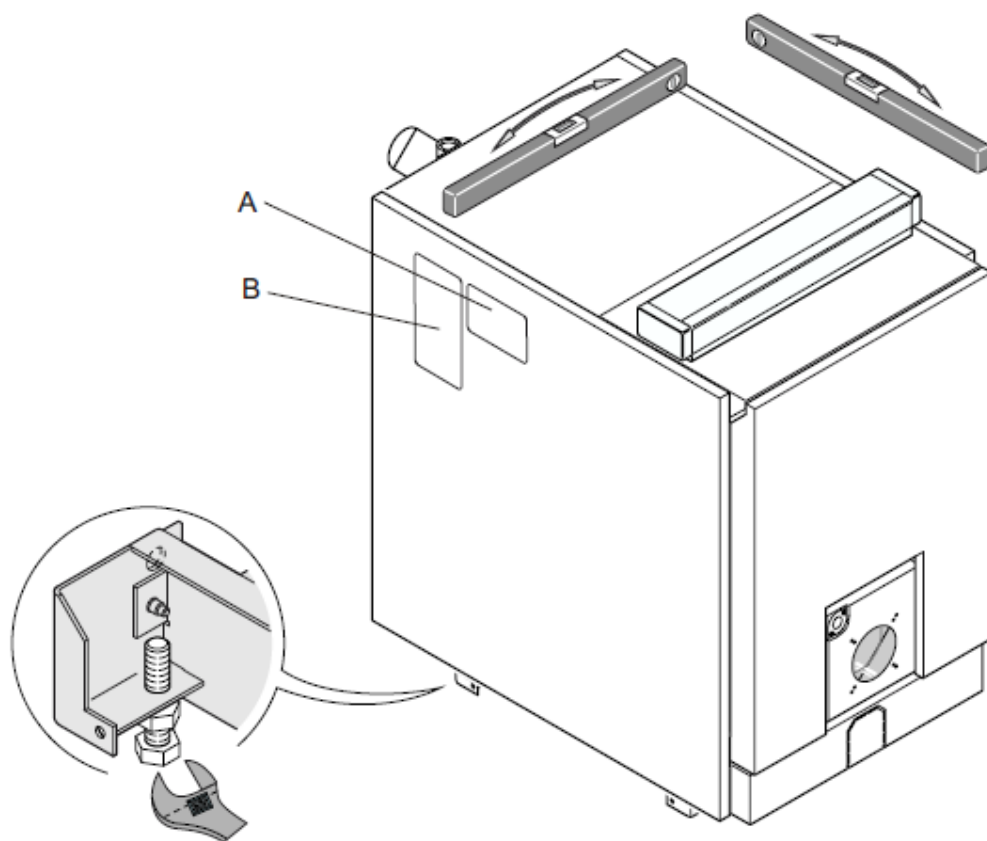

- A: Stick warning label
- B: Stick data plate

